

F#	VALUE	FUNCTION	CONNECTOR
F1	2	BUZZER	J3,3
F2	5	STEP LIGHTS IGN	J4,1
F3	15	BACK UP CAMERA	J3,6
F4	NA	NOT USED	-179-J
F5	NA	NOT USED	J11,1
F6	10	AC IGNITION	J4,2
F7	10	HEATER SHUTOFF/PUMP	-177-E
F8	10	DOME/CENTER LIGHT	J11,2/J11,3/J61
F9	15	HEAT 1	-177-G
F10	5	F CLEARANCE/SWITCH	J1,2/J1,3/J9,1
F11	2	FLASHER/REAR DR BUZZ RLY	J3,5/-178-C
F12	15	RELAY POWER/CAMERA	J9,2/J10,2
F13	NA	NOT USED	J3,4
F14	10	DASH SWITCH IGN	J3,5
F15	2	EXIT LIGHT IGN	J4,4/J8,1
F16	NA	NOT USED	J7,1
F17	25	DOOR BATTERY	J2,1
F18	10	DOOR SWITCH, LIFT, LIFT LIGHTS	J1,1
F19	15	RADIO BATTERY/CAMERA	J2,2
F20		SPARE IGNITION	J3,2
F21		SPARE IGNITION	J3,1
F22		SPARE BATTERY	J2,3
F23		SPARE BATTERY	J2,4
F24		SPARE BATTERY	J2,5

REVISIONS			
REV.	BY	DATE	DESCRIPTION

PRECISIONWORKS MANUFACTURING 120 9TH AVE. E-4 LONGMONT, CO 80501		TITLE: Electrical Panel Fuse Values	
THIS DRAWING IS THE PROPERTY OF PRECISIONWORKS MANUFACTURING AND IS NOT TO BE DUPLICATED OR USED IN ANY WAY DETRIMENTAL TO THEIR BEST INTEREST.		ADDITIONAL INFO:	
MATERIAL SPEC:	SIZE: C	RELEASE NO. 24400-RevB	DWG NO.
MODEL: Champion	SCALE: NTS	DATE: 11/27/2013	SHEET

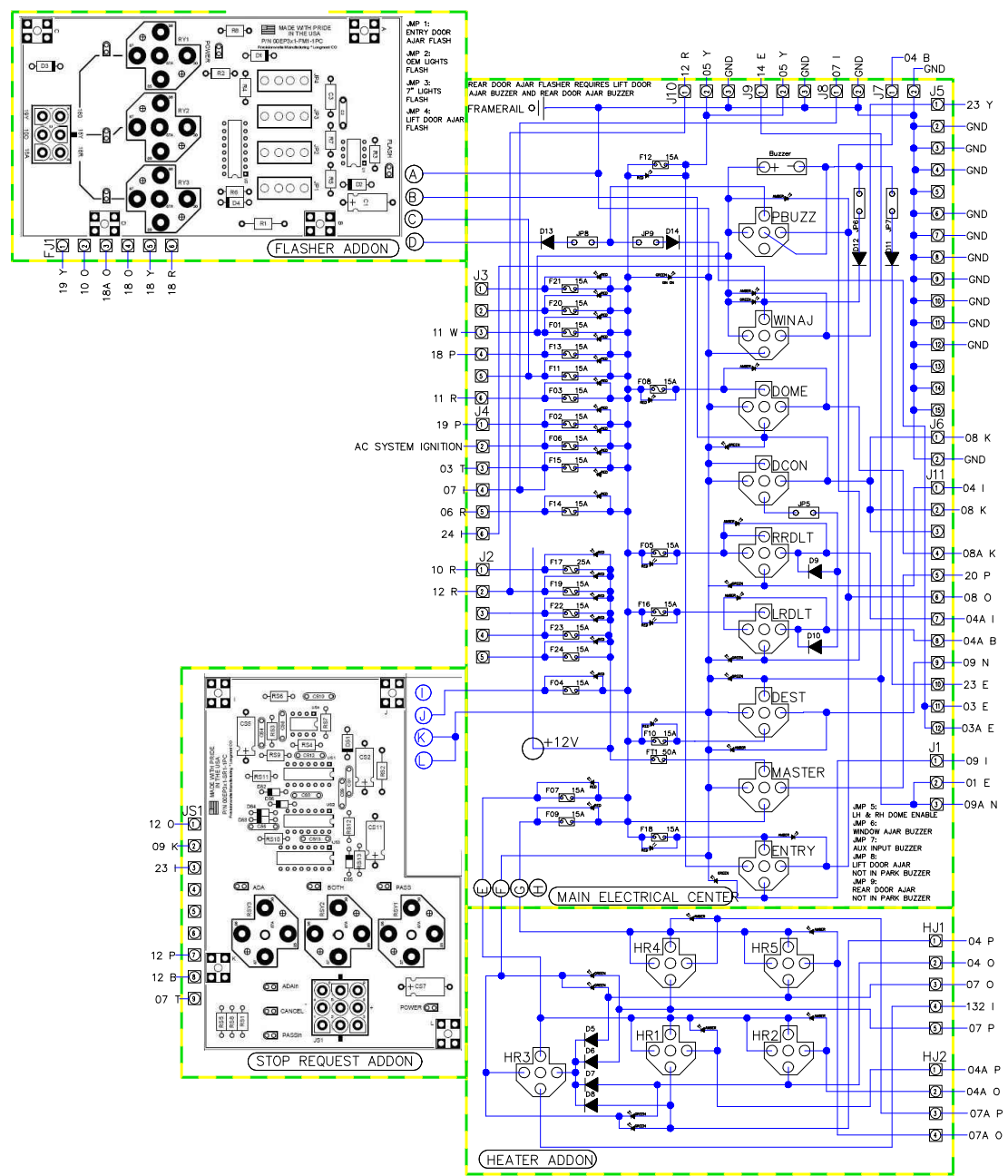

REV.	BY	DATE	DESCRIPTION	RELEASE #
C	FW	6/7/13	UPDATED MSG TO HARNESS PRINTS	
B	FW	7/21/13	UPDATED MSG TO HARNESS PRINTS	
A	FW	5/5/09	UPDATED ADDON CARDS	

COLOR CODES	
B	BLUE
E	GREY
G	GREEN
K	BLACK
I	PINK
N	BROWN
O	ORANGE
P	PURPLE
R	RED
T	TAN
Y	YELLOW
W	WHITE

LEGEND	
—○—	CONNECTION
---	NO CONNECTION
— —	DIODE
—F—	FUSE
—S—	SPEAKER
—SW—	SWITCH
—DSW—	DUAL SWITCH
—R—	RHEOSTAT
—L—	LED
—J—	JUMPER
—G—	GROUND
—C—	CONNECTOR
—2—	2 WIRE LIGHT
—3—	3 WIRE LIGHT

PRECISIONWORKS MANUFACTURING 120 8TH AVE. E. 4 LONGMONT, CO 80501		TITLE: EP3_Panel	
MATERIAL SPEC.		ADDITIONAL INFO:	
MODEL: Champion	SCALE: NTS	RELEASE NO. C	DWG. NO. 24400-RevB
		DATE: 11/27/2013	SHEET: 3

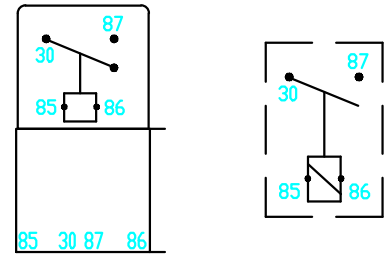

12 VOLT
RELAY

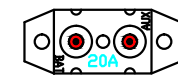

POST BREAKER

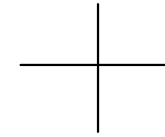

WIRE NOT CONNECTED



GROUND LOCATION

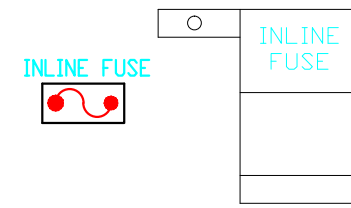

INLINE FUSE



GROUND INPUT

POWER STUD

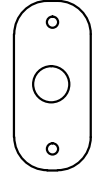

POWER STUD



BREAKER



CONNECTION POINT



DIODE

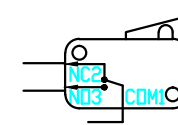

MICRO SWITCH

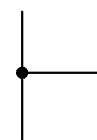

WIRE CONNECTED



BATTERY DISCONNECT

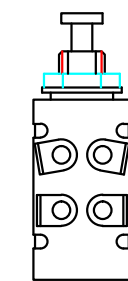

DPST JAMB SWITCH

WIRE COLOR CODES

COLOR CODES			
B	BLUE	O	ORANGE
E	GREY	P	PURPLE
G	GREEN	R	RED
K	BLACK	T	TAN
I	PINK	Y	YELLOW
N	BROWN	W	WHITE

COLOR CODES			
B	BLUE	O	ORANGE
E	GREY	P	PURPLE
G	GREEN	R	RED
K	BLACK	T	TAN
I	PINK	Y	YELLOW
N	BROWN	W	WHITE

LEGEND	
	CONNECTION
	NO CONNECTION
	DIODE
	FUSE
	SPEAKER
	SWITCH
	DUAL SWITCH
	RHEOSTAT
	LED
	JUMPER
	GROUND
	CONNECTOR
	2 WIRE LIGHT
	3 WIRE LIGHT

REVISIONS			
REV.	BY	DATE	RELEASE #

PRECISIONWORKS MANUFACTURING 120 9TH AVE E-4 LONGMONT, CO 80501		TITLE: Legend 1	
THIS DRAWING IS THE PROPERTY OF PRECISIONWORKS MANUFACTURING AND IS NOT TO BE DUPLICATED OR USED IN ANY WAY DETRIMENTAL TO THEIR BEST INTEREST.		ADDITIONAL INFO:	
MATERIAL SPEC:	SCALE:	RELEASE NO.:	DWG NO.:
		C	24400-RevB
MODEL: Champion	SCALE: NTS	DATE: 11/27/2013	SHEET:

A-CW/D-CW

C193-P 1 20P IGNITION TRG

FEMALE CONNECTOR 12010973
CBI #39-7185-5
MALE TERMINAL 12124582-L
CBI #39-7096-9
SEAL 12015323-V
CBI #39-7098-5

B	GND	GROUND
A	09Q	ENTRY LIGHTS

BLUNT CUT WIRE



C113

1	GND	GROUND
2	09W	DOOR CLOSE
3	09Y	DOOR OPEN
4	10R	DOOR POWER

C161

1		NOT USED
2	18W	REVERSE LIGHTS
3	18Y	LEFT TURN
4	09N	MARKER LIGHTS
5	18R	RIGHT TURN
6	09B	BRAKE LIGHTS

C215

1		NOT USED
2	18W	REVERSE LIGHTS
3	18Y	LEFT TURN
4	09N	MARKER LIGHTS
5	18R	RIGHT TURN
6	09B	BRAKE LIGHTS

PLUG CONNECTOR
AMP 1-480702-0
CBI #39-7154-0
SOCKET TERMINALS 350550-1
CBI #39-7155-3

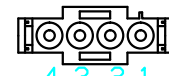

CAP CONNECTOR
AMP 1-480705-0
CBI #39-7154-5
SOCKET TERMINALS 350550-1
CBI #39-7155-3

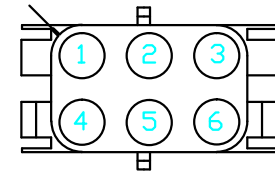

PLUG CONNECTOR
AMP 1-480704-0
CBI #39-7154-1
SOCKET TERMINALS 350550-1
CBI #39-7155-3

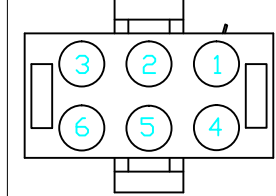

L915-QE

19P	DOOR OPEN SIG
GND	GROUND

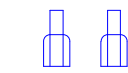

SPEAKER TERMINAL
MOLEX TERM. TAPE
QV-DIS FEM F/INS 16-1423
CBI #39-4426-1

L909-13

1	07I	EXIT LIGHTS
2	GND	GROUND

PLUG CONNECTOR
AMP 1-480698-0
CBI #39-7153-9
SOCKET TERMINALS 350550-1
CBI #39-7155-3

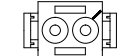

L906

10Q	LIFT DOOR AJAR
08T	LIFT LIGHTS

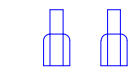

SPEAKER TERMINAL
MOLEX TERM. TAPE
QV-DIS FEM F/INS 16-1423
CBI #39-4426-1

C128

A	08T	LIFT LIGHTS
B	GND	GROUND

FEMALE CONNECTOR 12010973
CBI #39-7185-5
MALE TERMINAL 12124582-L
CBI #39-7096-9
SEAL 12015323-V
CBI #39-7098-5



C169

18W	REVERSE LIGHTS
GND	GROUND



C137

1	11R	RADIO IGN
2	12R	RADIO MEM
3	GND	GROUND
4		NOT USED
5	28W	LF SPKR +
6	28W/K	LF SPKR -
7	28E	RF SPKR +
8	28E/K	RF SPKR -
9	28P	RR SPKR +
10	28P/K	RR SPKR -
11	28G	LR SPKR +
12	28G/K	LR SPKR -

PLUG CONNECTOR
AMP 1-480708-0
CBI #39-7154-7
TERMINALS 350550-1
CBI #39-7155-3

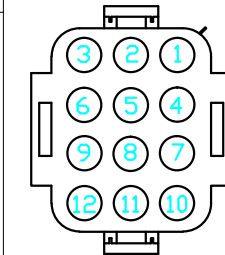

COLOR CODES

B	BLUE
E	GREY
G	GREEN
K	BLACK
J	PINK
N	BROWN
O	ORANGE
P	PURPLE
R	RED
T	TAN
Y	YELLOW
W	WHITE

LEGEND

- CONNECTION
- NO CONNECTION
- DIODE
- FUSE
- SPEAKER
- SWITCH
- DUAL SWITCH
- RHEOSTAT
- LED
- JUMPER
- GROUND
- CONNECTOR
- 2 WIRE LIGHT
- 3 WIRE LIGHT

REVISIONS

REV.	BY	DATE	DESCRIPTION	RELEASE #

PRECISIONWORKS MANUFACTURING
120 9TH AVE E-4
LONGMONT, CO 80501

TITLE: Legend 2

THIS DRAWING IS THE PROPERTY OF PRECISIONWORKS MANUFACTURING AND IS NOT TO BE DUPLICATED OR USED IN ANY WAY DETRIMENTAL TO THEIR BEST INTEREST.

MATERIAL SPEC: C RELEASE NO. DWG NO. 24400-RevB

MODEL: Champion SCALE DATE 11/27/2013 SHEET 5 of 23

C147-PW	A	09N	MARKER LIGHT
	B	18Y	LH TURN SIGNAL
	C	GND	GROUND

MALE CONNECTOR 12020829
CBI #39-7214-5
MALE TERMINAL 12124582-L
CBI #39-7096-9
SEAL 12015323-V
CBI #39-7098-5

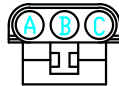

C187-P	1	10B	LIFT POWER
	2	R	NOT USED
	3	06Y	GATEWAY PWR
	4	100	LIFT DOOR

PLUG CONNECTOR
AMP 1-480702-0
CBI #39-7154-0
SOCKET TERMINALS 350550-1
CBI #39-7155-3



C189	1	07I	EXIT LIGHTS
	2	GND	GROUND

CAP CONNECTOR
AMP 1-480699-0
CBI #39-7154-3
PIN TERMINALS 350547-1
CBI #39-7155-2

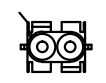

C153	1	09N	MARKER LIGHT
	2	GND	GROUND

CAP CONNECTOR
AMP 1-480699-0
CBI #39-7154-3
PIN TERMINALS 350547-1
CBI #39-7155-2

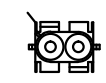

C140-P	1	09N	MARKER LIGHT
	2	09B	BRAKE LIGHT
	3	GND	GROUND

PLUG CONNECTOR
AMP 1-480700-0
CBI #B13-1914
PIN TERMINALS 350547-1
CBI #39-7155-2



C146-P	1	09N	MARKER LIGHT
	2	09B	BRAKE LIGHT
	3	GND	GROUND

PLUG CONNECTOR
AMP 1-480700-0
CBI #B13-1914
PIN TERMINALS 350547-1
CBI #39-7155-2



C144-P	1	18W	REVERSE SIGNAL
	2	GND	GROUND

PLUG CONNECTOR
AMP 1-480698-0
CBI #39-7153-9
PIN TERMINALS 350547-1
CBI #39-7155-2



C142-P	1	18R	RH TURN SIGNAL
	2	GND	GROUND

PLUG CONNECTOR
AMP 1-480698-0
CBI #39-7153-9
PIN TERMINALS 350547-1
CBI #39-7155-2



C141-PW	A	09N	MARKER LIGHT
	B	18R	RH TURN SIGNAL
	C	GND	GROUND

MALE CONNECTOR 12020829
CBI #39-7214-5
MALE TERMINAL 12124582-L
CBI #39-7096-9
SEAL 12015323-V
CBI #39-7098-5

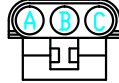

C103-C	1	02P	AUX POWER
	2	18W	REVERSE SIGNAL
	3	GND	GROUND
	4	09N	MARKER LIGHTS
	5		NOT USED
	6	18R	RIGHT TURN SIG
	7	03T	REAR LUGG. LT
	8	GND	GROUND
	9	09B	BRAKE LIGHTS
	10	23Y	WINDOW AJAR
	11	18Y	LEFT TURN SIG
	12	07I	EXIT LIGHTS
	13		NOT USED
	14	180	7" LIGHT
	15	03E	REAR DOOR AJAR

CAP CONNECTOR
AMP 1-480711-0
CBI #39-7155-1
TER. 350547-1
CBI #39-7155-2

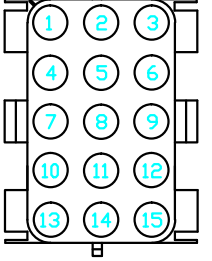

C103-P	1	02P	AUX POWER
	2	18W	BUZZER ALARM
	3	GND	GROUND
	4	09N	MARKER LIGHTS
	5		NOT USED
	6	18R	RIGHT TURN SIG
	7	03T	REAR LUGG. LT
	8	GND	GROUND
	9	09B	BRAKE LIGHTS
	10	23Y	WINDOW AJAR
	11	18Y	LEFT TURN SIG
	12	07I	EXIT LIGHTS
	13		NOT USED
	14	180	7" LIGHT
	15	03E	REAR DOOR AJAR

PLUG CONNECTOR
AMP 1-480710-0
CBI #39-7154-8
TER 350550-1
CBI #39-7155-3

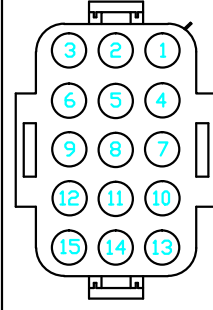

C068F	03AE	REAR DOOR AJAR
-------	------	----------------

SPEAKER TERMINAL
MOLEX TERM. TAPE
QV-DIS FEM F/INS 16-1423
CBI #39-4426-1



COLOR CODES	
B	BLUE
E	GREY
G	GREEN
K	BLACK
J	PINK
N	BROWN
O	ORANGE
P	PURPLE
R	RED
T	TAN
Y	YELLOW
W	WHITE

LEGEND	
○	CONNECTION
○	NO CONNECTION
⏏	DIODE
⏏	FUSE
⏏	SPEAKER
⏏	SWITCH
⏏	DUAL SWITCH
⏏	RHEOSTAT
⏏	LED
⏏	JUMPER
⏏	GROUND
⏏	CONNECTOR
⏏	2 WIRE LIGHT
⏏	3 WIRE LIGHT

REVISIONS			
REV.	BY	DATE	DESCRIPTION
C	PW	8/1/13	UPDATED MISC TO HARNESS PRINTS
B	PW	7/21/08	UPDATED MISC TO HARNESS PRINTS
A	PW	5/5/08	UPDATED ADDON CARDS

PRECISIONWORKS MANUFACTURING 120 9TH AVE E-4 LONGMONT, CO 80501		TITLE: Legend 3	
THIS DRAWING IS THE PROPERTY OF PRECISIONWORKS MANUFACTURING AND IS NOT TO BE DUPLICATED OR USED IN ANY WAY DETRIMENTAL TO THEIR BEST INTEREST.		ADDITIONAL INFO:	
MATERIAL SPEC:	SCALE:	RELEASE NO.:	DWG NO.:
Champion	NTS	11/27/2013	24400-RevB
		DATE:	SHEET:
		11/27/2013	6 OF 23

C148-P	1	18Y	LH TURN SIGNAL
	2	GND	GROUND

PLUG CONNECTOR
AMP 1-480698-0
CBI #39-7153-9
PIN TERMINALS 350547-1
CBI #39-7155-2



C117-C	1	08K	DOME LIGHTS
	2	GND	GROUND

CAP CONNECTOR
AMP 1-480699-0
CBI #39-7154-3
PIN TERMINALS 350547-1
CBI #39-7155-2



C116-C	1	09W	DOOR CLOSE
	2	GND	GROUND
	3	09Y	DOOR OPEN
	4	10R	DOOR BATT PWR

CAP CONNECTOR
AMP 1-480703-0
CBI #39-7154-4
PIN TERMINALS 350547-1
CBI #39-7155-2

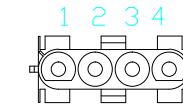

C150-P	1	18W	LH REVERSE LT
	2	GND	GROUND

PLUG CONNECTOR
AMP 1-480698-0
CBI #39-7153-9
PIN TERMINALS 350547-1
CBI #39-7155-2



C108-C	1	04P	HEATER #2 HIGH
	2		
	3	04Q	HEATER #2 LOW
	4	GND	HEATER GROUND

CAP CONNECTOR
AMP 1-480703-0
CBI #39-7154-4
PIN TERMINALS 350547-1
CBI #39-7155-2

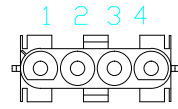

C110-C	1	08K	DOME LIGHTS
	2	GND	GROUND

CAP CONNECTOR
AMP 1-480699-0
CBI #39-7154-3
PIN TERMINALS 350547-1
CBI #39-7155-2



C165-C	1	GND	GROUND
	2	09Q	ENTRY LIGHTS

CAP CONNECTOR
AMP 1-480699-0
CBI #39-7154-3
PIN TERMINALS 350547-1
CBI #39-7155-2



C190E/F-C	A	09N	MARKER LIGHTS
	B	GND	GROUND

FEMALE CONNECTOR 12010973
CBI #39-7185-5
MALE TERMINAL 12124582-L
CBI #39-7096-9
SEAL 12015323-V
CBI #39-7098-5

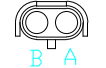

C108A-P	1	04P	HEATER #2 HIGH
	2		
	3	04Q	HEATER #2 LOW
	4	GND	HEATER GROUND

PLUG CONNECTOR
AMP 1-480702-0
CBI #39-7154-0
SOCKET TERMINALS 350550-1
CBI #39-7155-3



C110-P	1	08K	DOME LIGHTS
	2	GND	GROUND

PLUG CONNECTOR
AMP 1-480698-0
CBI #39-7153-9
SOCKET TERMINALS 350550-1
CBI #39-7155-3

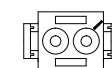

C165-P	1	GND	GROUND
	2	09Q	ENTRY LIGHTS

PLUG CONNECTOR
AMP 1-480698-0
CBI #39-7153-9
SOCKET TERMINALS 350550-1
CBI #39-7155-3

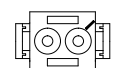

C190-C	1	09N	MARKER LIGHTS
	2	GND	GROUND

CAP CONNECTOR
AMP 1-480699-0
CBI #39-7154-3
PIN TERMINALS 350547-1
CBI #39-7155-2



C108-P	1	07P	HEATER #1 HIGH
	2		
	3	07Q	HEATER #1 LOW
	4	GND	HEATER GROUND

PLUG CONNECTOR
AMP 1-480702-0
CBI #39-7154-0
SOCKET TERMINALS 350550-1
CBI #39-7155-3

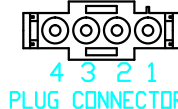

C157-C	1	07I	EXIT LIGHTS
	2	GND	GROUND

CAP CONNECTOR
AMP 1-480699-0
CBI #39-7154-3
PIN TERMINALS 350547-1
CBI #39-7155-2



C163B-P	1	08AI	LIFT LIGHTS
	2	10B	LIFT POWER
	3	GND	GROUND
	4	10D	LIFT DOOR AJAR

PLUG CONNECTOR
AMP 1-480702-0
CBI #39-7154-0
PIN TERMINALS 350547-1
CBI #39-7155-2



C145-P	1	09B	CEN.BRAKE LIGHT
	2	GND	GROUND

PLUG CONNECTOR
AMP 1-480698-0
CBI #39-7153-9
PIN TERMINALS 350547-1
CBI #39-7155-2

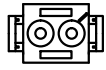

C109-C	1	09N	MARKER LIGHT
	2	GND	GROUND

CAP CONNECTOR
AMP 1-480699-0
CBI #39-7154-3
PIN TERMINALS 350547-1
CBI #39-7155-2



C106-C	1	02P	AUX POWER
	2	18W	REVERSE SIGNAL
	3	GND	GROUND
	4	09N	MARKER LIGHTS
	5		NOT USED
	6	18R	RIGHT TURN SIG
	7	03T	REAR LUGG. LT
	8	GND	GROUND
	9	09B	BRAKE LIGHTS
	10	23Y	WINDOW AJAR
	11	18Y	LEFT TURN SIG
	12	07I	EXIT LIGHTS
	13		NOT USED
	14	18Q	7" LIGHT
	15	03E	REAR DOOR AJAR

CAP CONNECTOR
AMP 1-480711-0
CBI #39-7155-1
TER. 350547-1
CBI #39-7155-2

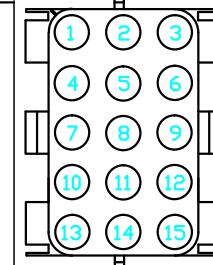

C106-P	1	02P	AUX POWER
	2	18W	BUZZER ALARM
	3	GND	GROUND
	4	09N	MARKER LIGHTS
	5		NOT USED
	6	18R	RIGHT TURN SIG
	7	03T	REAR LUGG. LT
	8	GND	GROUND
	9	09B	BRAKE LIGHTS
	10	23Y	WINDOW AJAR
	11	18Y	LEFT TURN SIG
	12	07I	EXIT LIGHTS
	13		NOT USED
	14	18Q	7" LIGHT
	15	03E	REAR DOOR AJAR

PLUG CONNECTOR
AMP 1-480710-0
CBI #39-7154-8
TER. 350550-1
CBI #39-7155-3

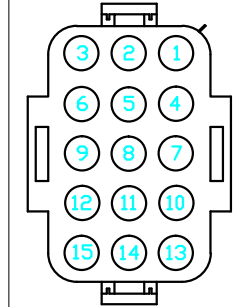

C129	28E	RT FRONT SPK
	28E/K	RT FRONT SPK

SPEAKER TERMINAL
MOLEX TERM. TAPE
QV-DIS FEM F/INS 16-1423
CBI #39-4426-1

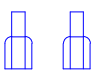

L907	08AI	LIFT LIGHTS
	GND	GROUND

SPEAKER TERMINAL
MOLEX TERM. TAPE
QV-DIS FEM F/INS 16-1423
CBI #39-4426-1



REV.	BY	DATE	DESCRIPTION	RELEASE #

COLOR CODES	
B	BLUE
E	GREY
G	GREEN
K	BLACK
I	PINK
N	BROWN
O	ORANGE
P	PURPLE
R	RED
T	TAN
Y	YELLOW
W	WHITE

LEGEND	
○	CONNECTION
○	NO CONNECTION
⊖	DIODE
⊕	FUSE
⊖	SPEAKER
⊖	SWITCH
⊖	DUAL SWITCH
⊖	RHEOSTAT
⊖	LED
⊖	JUMPER
⊖	GROUND
⊖	CONNECTOR
⊖	2 WIRE LIGHT
⊖	3 WIRE LIGHT

PRECISIONWORKS MANUFACTURING 120 9TH AVE E-4 LONGMONT, CO 80501	TITLE: Legend 4
THIS DRAWING IS THE PROPERTY OF PRECISIONWORKS MANUFACTURING AND IS NOT TO BE DUPLICATED OR USED IN ANY WAY DETRIMENTAL TO THEIR BEST INTEREST.	ADDITIONAL INFO:
MATERIAL SPEC:	SCALE: RELEASE NO. DWG NO. C 24400-RevB
MODEL: Champion	DATE: 11/27/2013 SHEET

STANDARD DOOR

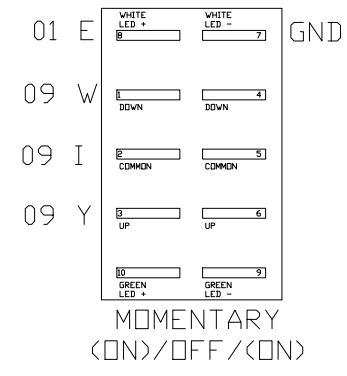

DOOR ACTUATED INTERIOR LIGHTS

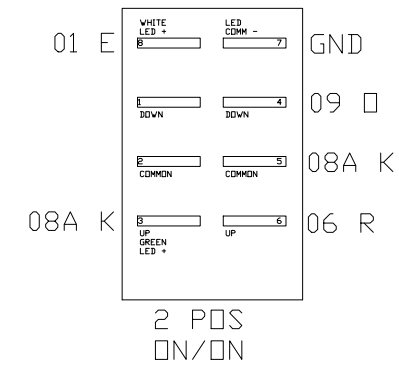

LIFT MASTER

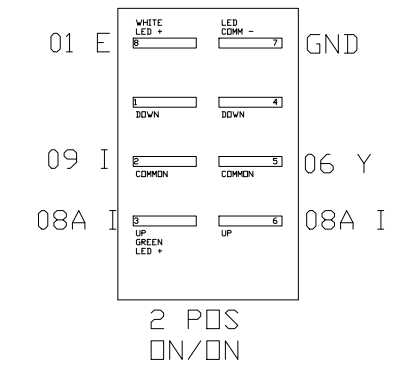

DEFROST FAN

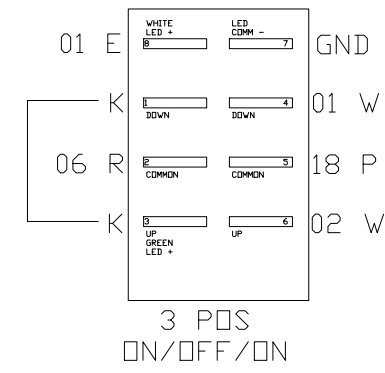

REV.	BY	DATE	DESCRIPTION	RELEASE #
C	FW	8/1/13	UPDATED MISC TO HARNESS PRINTS	
B	FW	7/21/08	UPDATED MISC TO HARNESS PRINTS	
A	FW	5/5/08	UPDATED ADDON CARDS	

LEGEND	
	CONNECTION
	NO CONNECTION
	DIODE
	FUSE
	SPEAKER
	SWITCH
	DUAL SWITCH
	RHEOSTAT
	LED
	JUMPER
	GROUND
	CONNECTOR
	2 WIRE LIGHT
	3 WIRE LIGHT

PRECISIONWORKS MANUFACTURING 120 9TH AVE. E-4 LONGMONT, CO 80501		TITLE: Switch_Wiring	
THIS DRAWING IS THE PROPERTY OF PRECISIONWORKS MANUFACTURING AND IS NOT TO BE DUPLICATED OR USED IN ANY WAY DETRIMENTAL TO THEIR BEST INTERESTS.		ADDITIONAL INFO:	
MATERIAL SPEC:	SCALE: NTS	RELEASE NO. C	DWG NO. 24400-RevB
MODEL: Champion	SCALE: NTS	DATE: 11/27/2013	SHEET

REV	BY	DATE	DESCRIPTION	RELEASE #
C	FW	8/1/13	UPDATED MISC TO HARNESS PRINTS	
B	FW	7/21/10	UPDATED MISC TO HARNESS PRINTS	
A	FW	5/9/08	UPDATED ADDON CARDS	

COLOR CODES	
B	BLUE
E	GREY
G	GREEN
K	BLACK
I	PINK
N	BROWN
O	ORANGE
P	PURPLE
R	RED
T	TAN
Y	YELLOW
W	WHITE

LEGEND	
—	CONNECTION
- - -	NO CONNECTION
⊕	DIODE
⊖	FUSE
SPK	SPEAKER
SW	SWITCH
DS	DUAL SWITCH
RH	RHEOSTAT
LED	LED
J	JUMPER
⊕	GROUND
⊖	CONNECTOR
—	2 WIRE LIGHT
—	3 WIRE LIGHT

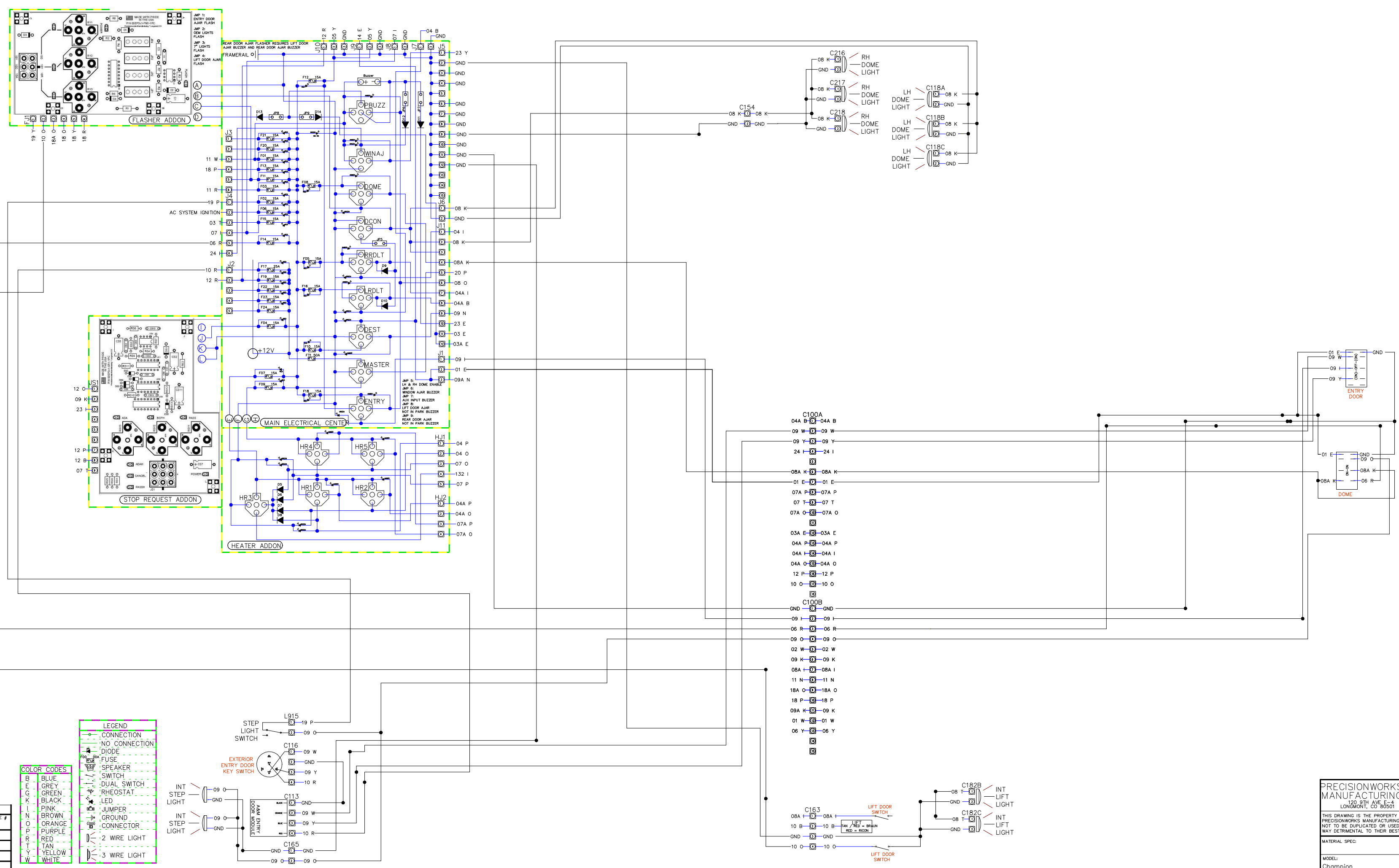

PRECISIONWORKS MANUFACTURING 120 8th Ave S LONGMONT, CO 80501		TITLE Interior_Lighting	
MATERIAL SPEC:		SCALE	
MODEL: Champion		DATE: 11/27/2013	
THIS DRAWING IS THE PROPERTY OF PRECISIONWORKS MANUFACTURING AND IS NOT TO BE REPRODUCED OR USED IN ANY WAY DETRIMENTAL TO THEIR BEST INTEREST.		ADDITIONAL INFO:	
SIZE: C		RELEASE NO: 24400-RevB	
SHEET		SHEET	

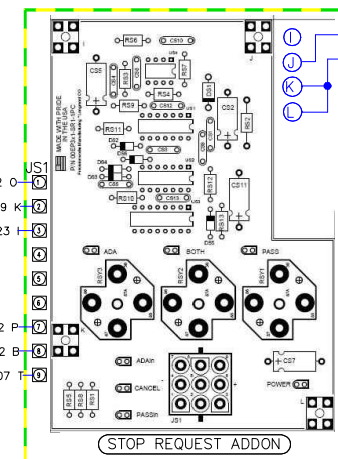
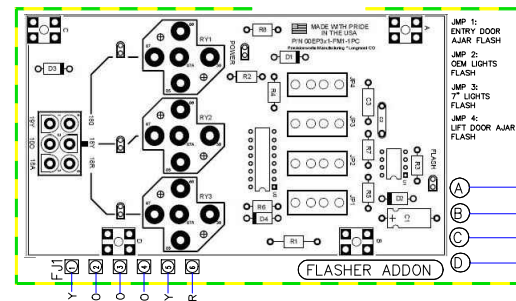
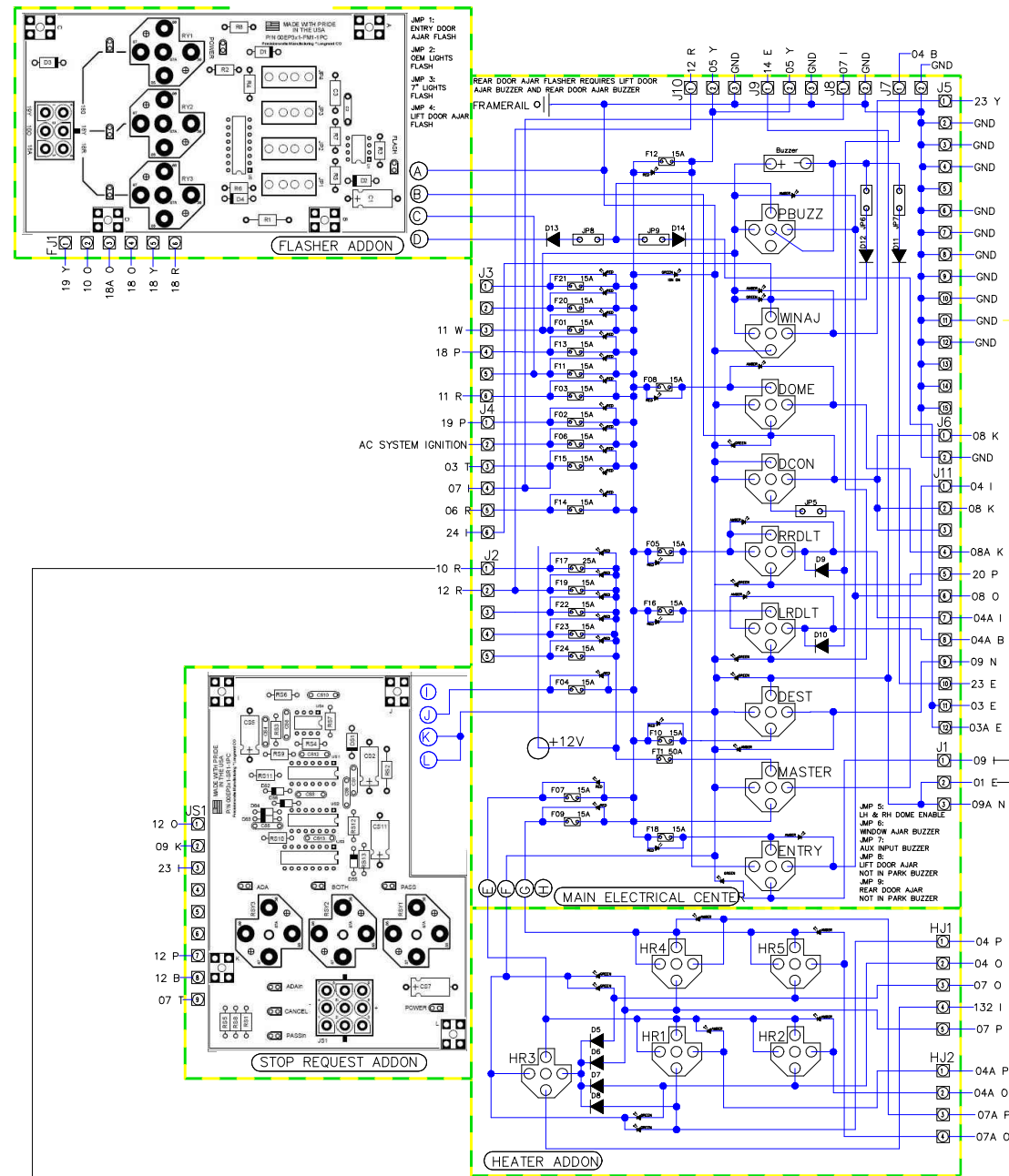

REV.	BY	DATE	DESCRIPTION	RELEASE #
C	PW	8/17/13	UPDATED MSC TO HARNESS PRINTS	
B	PW	7/21/04	UPDATED MSC TO HARNESS PRINTS	
A	PW	5/5/09	UPDATED ADDON CARDS	

COLOR CODES	
B	BLUE
G	GREEN
K	BLACK
I	PINK
N	BROWN
O	ORANGE
P	PURPLE
R	RED
T	TAN
Y	YELLOW
W	WHITE

LEGEND	
—	CONNECTION
---	NO CONNECTION
⏏	DIODE
⏏	FUSE
⏏	SPEAKER
⏏	SWITCH
⏏	DUAL SWITCH
⏏	RHEOSTAT
⏏	LED
⏏	JUMPER
⏏	GROUND
⏏	CONNECTOR
⏏	2 WIRE LIGHT
⏏	3 WIRE LIGHT

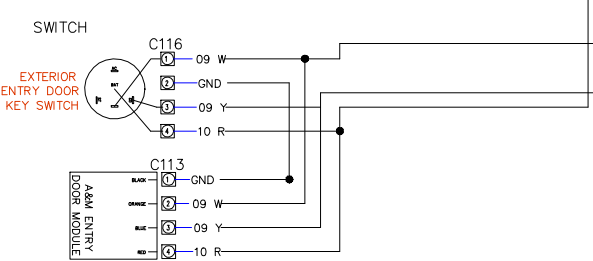

- C100A
- 04A B
- 09 W
- 09 Y
- 24 I
- 08A K
- 01 E
- 07A P
- 07 T
- 07A O
- 03A E
- 04A P
- 04A I
- 04A O
- 12 P
- 10 O
- C100B
- GND
- 09 I
- 06 R
- 09 O
- 02 W
- 09 K
- 08A I
- 11 N
- 18A O
- 18 P
- 09A K
- 01 W
- 06 Y

PRECISIONWORKS MANUFACTURING 100 9TH AVE E-4 LONGMONT, CO 80501		TITLE: Entrance_door_system	
THIS DRAWING IS THE PROPERTY OF PRECISIONWORKS MANUFACTURING AND IS NOT TO BE DUPLICATED OR USED IN ANY WAY DETRIMENTAL TO THEIR BEST INTEREST.		ADDITIONAL INFO:	
MATERIAL SPEC:	SCALE: C	RELEASE NO.:	DWG NO. 24400-RevB
MODEL: Champion	SCALE: NTS	DATE: 11/27/2013	SHEET:

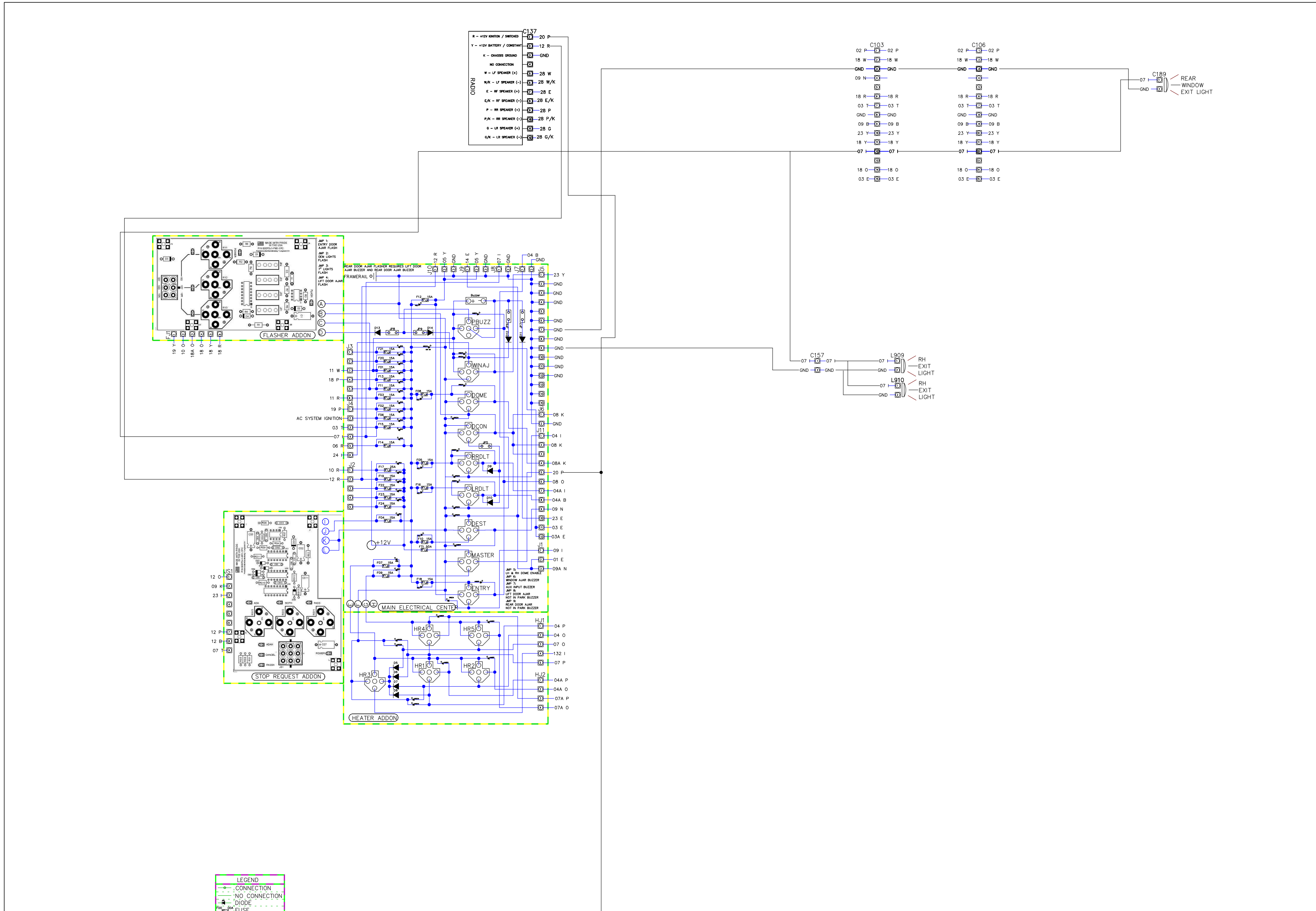

- C137**
- R - +12V IGNITION / SWITCHED
 - Y - +12V BATTERY / CONSTANT
 - X - CHASSIS GROUND
 - NO CONNECTION
 - W - LF SPEAKER (+)
 - W/R - LF SPEAKER (-)
 - E - RF SPEAKER (+)
 - E/K - RF SPEAKER (-)
 - P - RR SPEAKER (+)
 - P/K - RR SPEAKER (-)
 - G - LR SPEAKER (+)
 - G/K - LR SPEAKER (-)

- C103**
- 02 P - 02 P
 - 18 W - 18 W
 - GND - GND
 - 09 N - 09 N
 - 18 R - 18 R
 - 03 T - 03 T
 - GND - GND
 - 09 B - 09 B
 - 23 Y - 23 Y
 - 18 Y - 18 Y
 - 07 I - 07 I
 - 18 O - 18 O
 - 03 E - 03 E
- C106**
- 02 P - 02 P
 - 18 W - 18 W
 - GND - GND
 - 03 T - 03 T
 - GND - GND
 - 09 B - 09 B
 - 23 Y - 23 Y
 - 18 Y - 18 Y
 - 07 I - 07 I
 - 18 O - 18 O
 - 03 E - 03 E

C189

- 07 I - 07 I
- GND - GND

REAR WINDOW EXIT LIGHT

C157

- 07 I - 07 I
- GND - GND

L909

- 07 I - 07 I
- GND - GND

RH EXIT LIGHT

L910

- 07 I - 07 I
- GND - GND

RH EXIT LIGHT

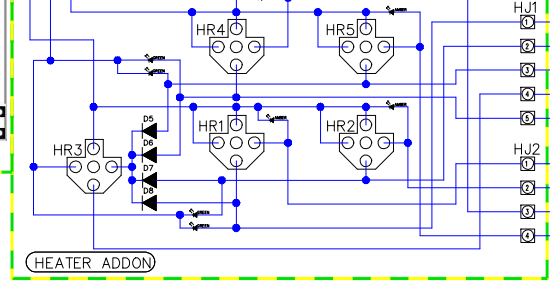
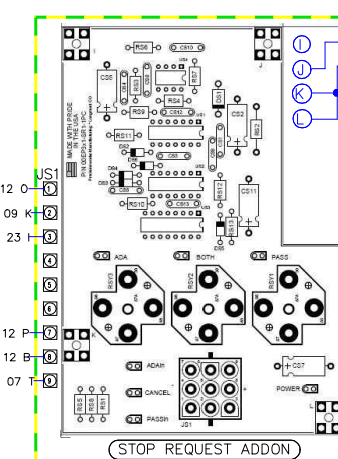
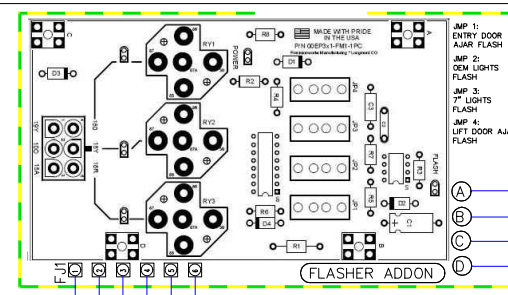

COLOR CODES

B	BLUE
F	GREY
C	GREEN
K	BLACK
I	PINK
N	BROWN
O	ORANGE
P	PURPLE
R	RED
T	TAN
Y	YELLOW
W	WHITE

LEGEND

○	CONNECTION
○	NO CONNECTION
△	DIODE
⊞	FUSE
⊞	SPEAKER
⊞	SWITCH
⊞	DUAL SWITCH
⊞	RHEOSTAT
⊞	LED
⊞	JUMPER
⊞	GROUND
⊞	CONNECTOR
⊞	2 WIRE LIGHT
⊞	3 WIRE LIGHT

REVISIONS

REV	BY	DATE	DESCRIPTION	RELEASE #
C	PW	8/7/13	UPDATED MISC TO HARNESS PRINTS	
B	PW	7/21/08	UPDATED MISC TO HARNESS PRINTS	
A	PW	5/5/08	UPDATED ADDON CARDS	

C133

- 20 P - 20 P
- 18 R - 18 R
- 18 Y - 18 Y

IGN/ACCY IN (+) CHASSIS RT TURN LT TURN

PRECISIONWORKS MANUFACTURING 100 9TH AVE E-4 LONGMONT, CO 80501	TITLE: Ignition_Control_circuits
THIS DRAWING IS THE PROPERTY OF PRECISIONWORKS MANUFACTURING AND IS NOT TO BE DUPLICATED OR USED IN ANY WAY DETRIMENTAL TO THEIR BEST INTEREST.	ADDITIONAL INFO:
MATERIAL SPEC:	REV: C
MODEL: Champion	RELEASE NO. 24400-RevB
SCALE: NTS	DATE: 11/27/2013
	SHEET

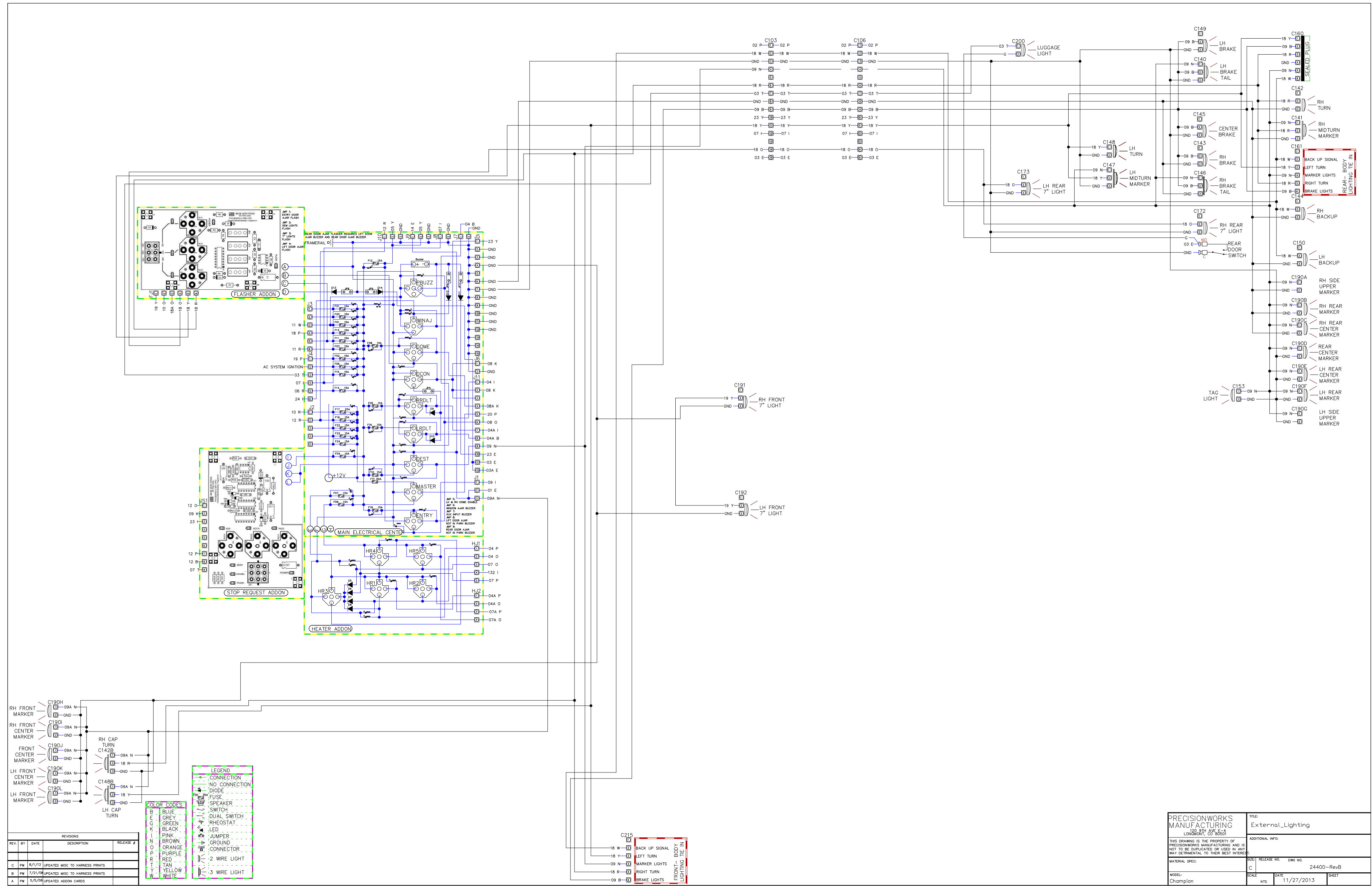

REV.	BY	DATE	DESCRIPTION	RELEASE #
C	PW	8/7/13	UPDATED MISC TO HARNESS PRINTS	
B	PW	7/21/09	UPDATED MISC TO HARNESS PRINTS	
A	PW	5/5/08	UPDATED ADDON CARDS	

COLOR CODES	
B	BLUE
C	GREY
G	GREEN
K	BLACK
I	PINK
N	BROWN
O	ORANGE
P	PURPLE
R	RED
T	TAN
Y	YELLOW
W	WHITE

LEGEND	
—	CONNECTION
---	NO CONNECTION
⏏	DIODE
⏏	FUSE
⏏	SPEAKER
⏏	SWITCH
⏏	DUAL SWITCH
⏏	RHEOSTAT
⏏	LED
⏏	JUMPER
⏏	GROUND
⏏	CONNECTOR
⏏	2 WIRE LIGHT
⏏	3 WIRE LIGHT

PRECISIONWORKS MANUFACTURING
 LONGMONT, CO 80501
 120 8TH AVE E-4

THIS DRAWING IS THE PROPERTY OF PRECISIONWORKS MANUFACTURING AND IS NOT TO BE DUPLICATED OR USED IN ANY WAY DETRIMENTAL TO THEIR BEST INTERESTS.

MATERIAL SPEC: _____

MODEL: Champion

SCALE: NTS

DATE: 11/27/2013

SHEET: _____

FILE: External_Lighting

RELEASE NO.: _____

DWG NO.: 24400-RevB

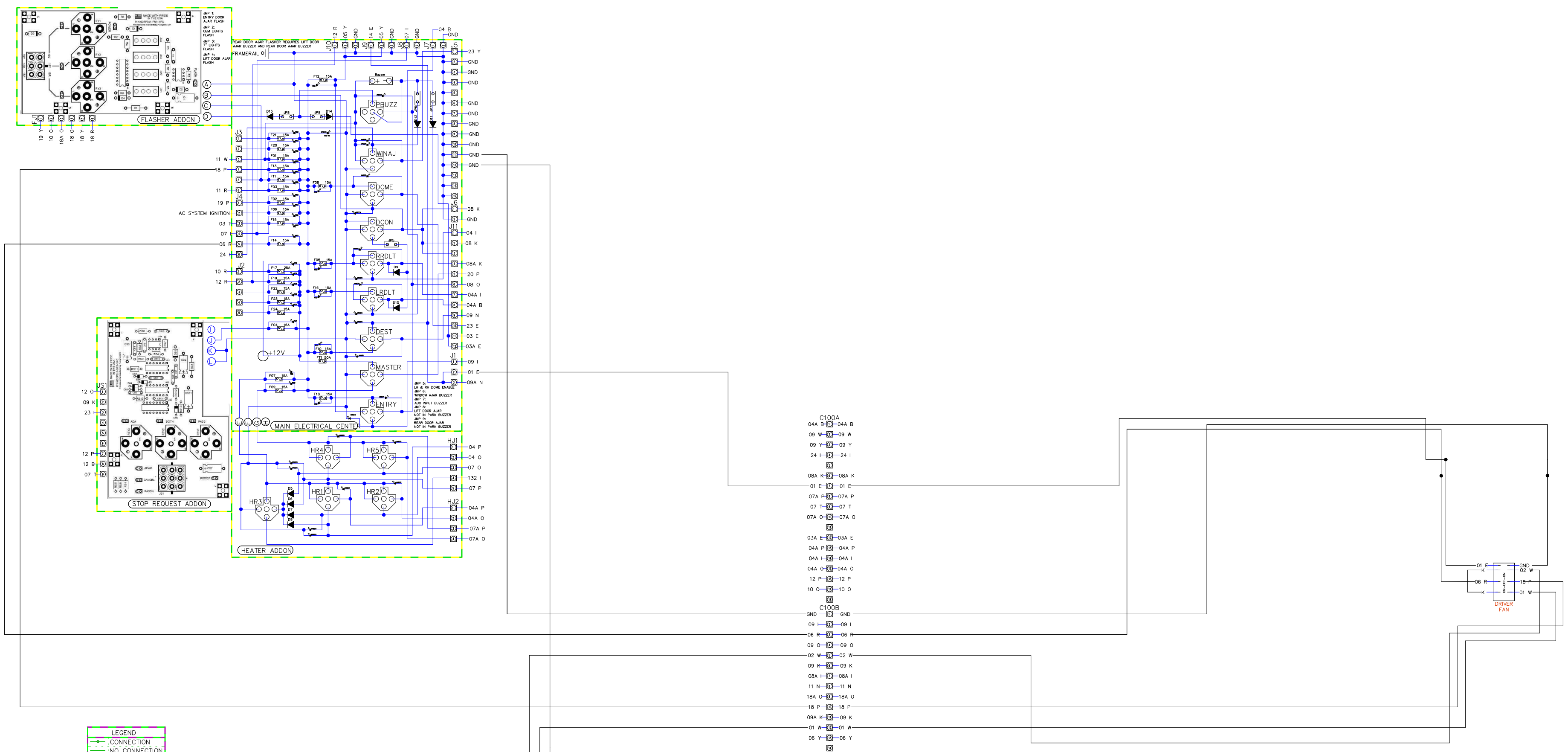

REV.	BY	DATE	DESCRIPTION	RELEASE #
C	FW	8/1/13	UPDATED MISC TO HARNESS PRINTS	
B	FW	7/21/08	UPDATED MISC TO HARNESS PRINTS	
A	FW	5/5/08	UPDATED ADDON CARDS	

COLOR CODES	
B	BLUE
E	GREY
G	GREEN
K	BLACK
L	PINK
N	BROWN
O	ORANGE
P	PURPLE
R	RED
T	TAN
Y	YELLOW
W	WHITE

LEGEND	
—	CONNECTION
—	NO CONNECTION
—	NO CONNECTION
—	DIODE
—	FUSE
—	SPEAKER
—	SWITCH
—	DUAL SWITCH
—	RHEOSTAT
—	LED
—	LUMPER
—	GROUND
—	CONNECTOR
—	2 WIRE LIGHT
—	3 WIRE LIGHT

PRECISIONWORKS MANUFACTURING 12000 HWY. E-4 LONGMONT, CO 80501	TITLE Aux_Heating_System
	ADDITIONAL INFO:
MATERIAL SPEC:	SIZE: RELEASE NO. DWG NO. C 24400-RevB
MODEL: Champion	SCALE: DATE SHEET NTS 11/27/2013

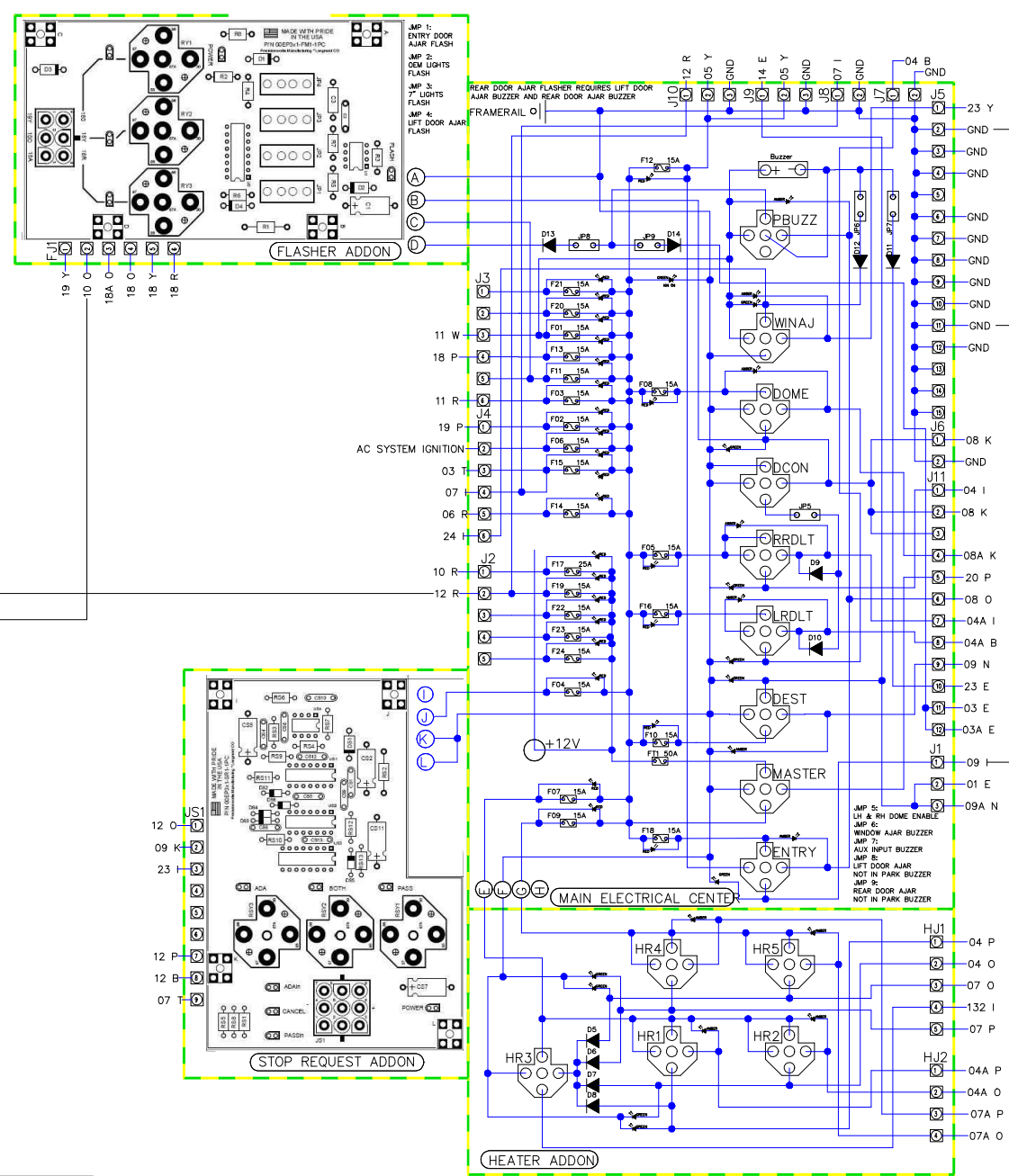

- C100A
- 04A B 04A B
- 09 W 09 W
- 09 Y 09 Y
- 24 H 24 I
- 08A K 08A K
- 01 E 01 E
- 07A P 07A P
- 07 T 07 T
- 07A O 07A O
- 03A E 03A E
- 04A P 04A P
- 04A I 04A I
- 04A O 04A O
- 12 P 12 P
- 10 O 10 O
- C100B
- GND GND
- 09 I 09 I
- 06 R 06 R
- 09 O 09 O
- 02 W 02 W
- 09 K 09 K
- 08A I 08A I
- 11 N 11 N SPARE (SW PANEL)
- 18A O 18A O
- 18 P 18 P
- 09A K 09A K
- 01 W 01 W
- 06 Y 06 Y

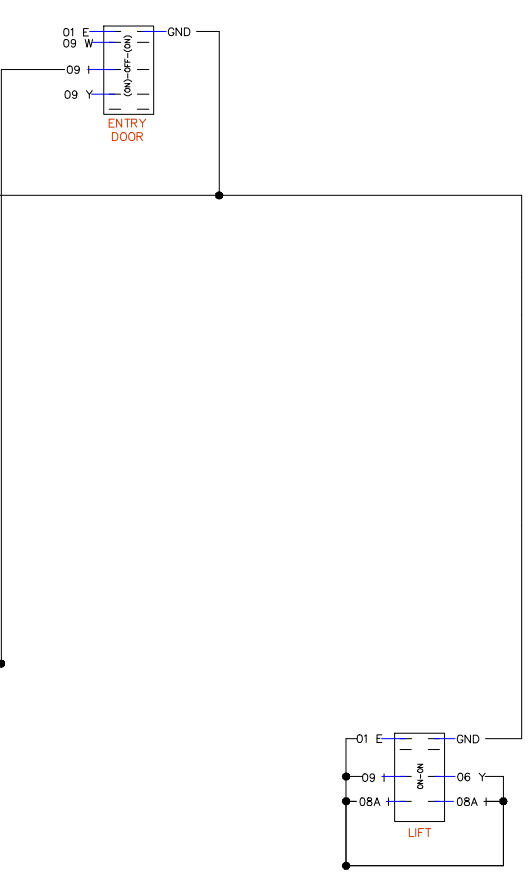
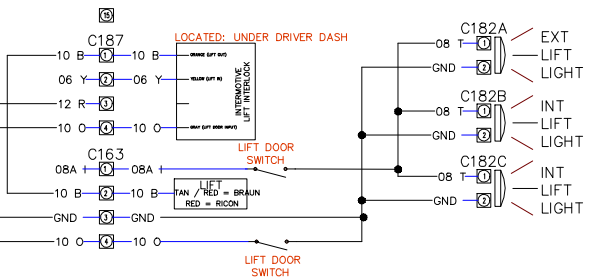

REV	BY	DATE	DESCRIPTION	RELEASE #
C	FW	8/7/13	UPDATED MSC TO HARNESS PRINTS	
B	FW	7/21/08	UPDATED MSC TO HARNESS PRINTS	
A	FW	5/5/08	UPDATED ADDON CARDS	

COLOR CODES		LEGEND	
B	BLUE	—	CONNECTION
E	GREY	—	NO CONNECTION
G	GREEN	—	DIODE
K	BLACK	—	FUSE
I	PINK	—	SPEAKER
N	BROWN	—	SWITCH
O	ORANGE	—	DUAL SWITCH
P	PURPLE	—	RHEOSTAT
R	RED	—	LED
T	TAN	—	JUMPER
Y	YELLOW	—	GROUND
W	WHITE	—	CONNECTOR
		—	2 WIRE LIGHT
		—	3 WIRE LIGHT

PRECISIONWORKS MANUFACTURING 100 3RD AVE S.E. LONGMONT, CO 80501	TITLE	Lift_System
	ADDITIONAL INFO:	
MATERIAL SPEC:	SIZE:	RELEASE NO. DWG NO.
MODEL:	SCALE:	DATE
Champion	NTS	11/27/2013
		SHEET
		24400-RevB

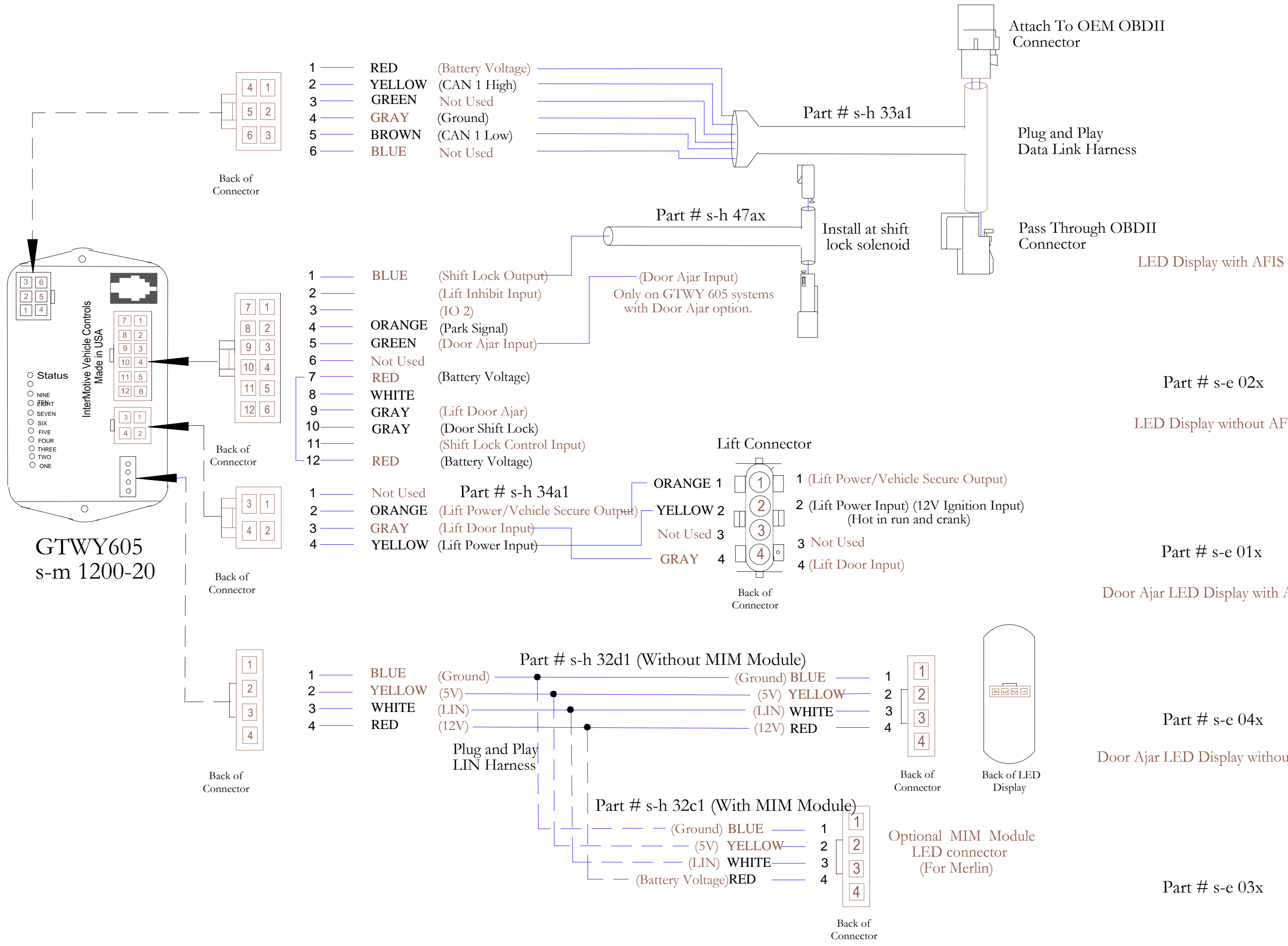

COLOR CODES	
B	BLUE
E	GREY
G	GREEN
K	BLACK
J	PINK
N	BROWN
O	ORANGE
P	PURPLE
R	RED
T	TAN
Y	YELLOW
W	WHITE

LEGEND	
○	CONNECTION
○	NO CONNECTION
⊗	DIODE
⊕	FUSE
⊞	SPEAKER
⊡	SWITCH
⊡	DUAL SWITCH
⊡	RHEOSTAT
⊡	LED
⊡	JUMPER
⊡	GROUND
⊡	CONNECTOR
⊡	2 WIRE LIGHT
⊡	3 WIRE LIGHT

REVISIONS				
REV.	BY	DATE	DESCRIPTION	RELEASE #

LIFT SYSTEM

PRECISIONWORKS MANUFACTURING 20 9TH AVE E-4 LONGMONT, CO 80501		TITLE: Lift_page2	
MATERIAL SPEC:		SCALE: NTS	
MODEL: Champion		DATE: 11/27/2013	
THIS DRAWING IS THE PROPERTY OF PRECISIONWORKS MANUFACTURING AND IS NOT TO BE DUPLICATED OR USED IN ANY WAY DETRIMENTAL TO THEIR BEST INTEREST.		SHEET: 24400-RevB	

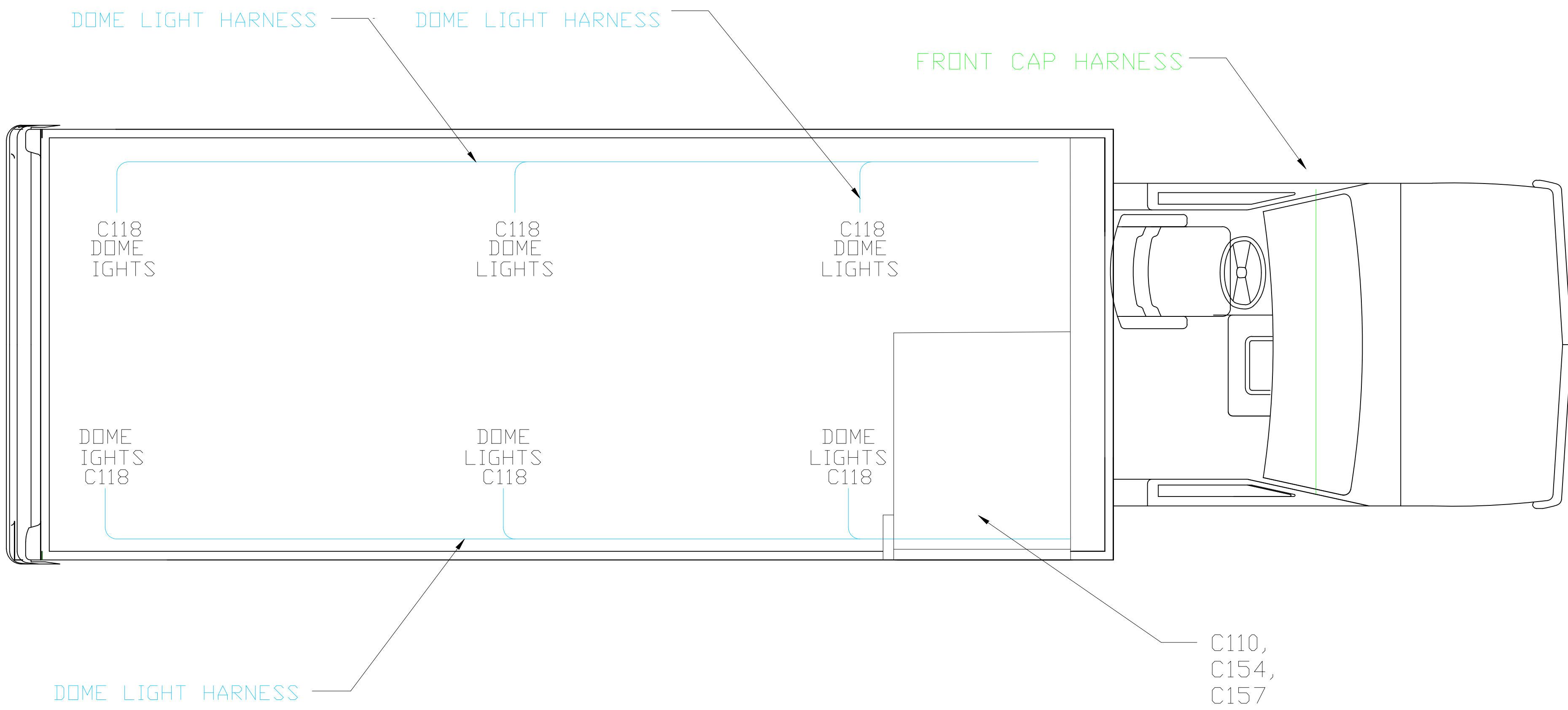

REV.	BY	DATE	DESCRIPTION	RELEASE #
C	PH	8/1/13	UPDATED MISC TO HARNESS PRINTS	
B	PH	7/21/08	UPDATED MISC TO HARNESS PRINTS	
A	PH	5/5/08	UPDATED ADDON CARDS	

COLOR CODES		LEGEND	
B	BLUE	—	CONNECTION
E	GREY	- - -	NO CONNECTION
G	GREEN	⏏	DIODE
K	BLACK	⏏	FUSE
L	PINK	⏏	SPEAKER
N	BROWN	⏏	SWITCH
O	ORANGE	⏏	DUAL SWITCH
P	PURPLE	⏏	RHEOSTAT
R	RED	⏏	LED
T	TAN	⏏	JUMPER
Y	YELLOW	⏏	GROUND
W	WHITE	⏏	CONNECTOR
		⏏	2 WIRE LIGHT
		⏏	3 WIRE LIGHT

PRECISIONWORKS MANUFACTURING		TITLE Dome_Lights	
THIS DRAWING IS THE PROPERTY OF PRECISIONWORKS MANUFACTURING AND IS NOT TO BE DUPLICATED OR USED IN ANY WAY DEEMED HARMFUL TO THEIR BEST INTERESTS		ADDITIONAL INFO:	
MATERIAL SPEC:	SCALE:	RELEASE NO.	DWG NO.
Champion	C		24400-RevB
MODEL:	DATE:	SHEET:	
	11/27/2013		

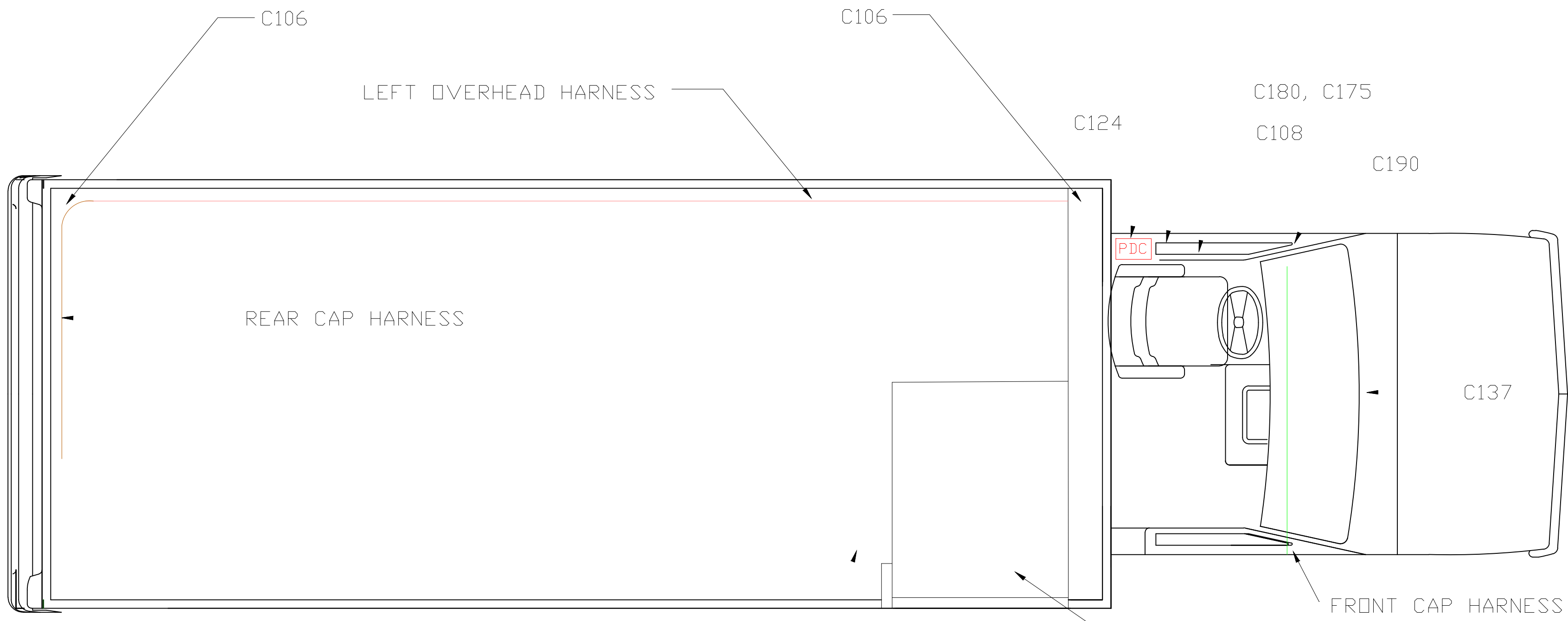

REVISIONS			
REV	BY	DATE	DESCRIPTION
C	FW	8/7/13	UPDATED MSC TO HARNESS PRINTS
B	FW	7/27/08	UPDATED MSC TO HARNESS PRINTS
A	FW	5/5/08	UPDATED ADDON CARDS

COLOR CODES	
B	BLUE
C	GREY
G	GREEN
K	BLACK
I	PINK
N	BROWN
O	ORANGE
P	PURPLE
R	RED
T	TAN
Y	YELLOW
W	WHITE

LEGEND	
—	CONNECTION
- - -	NO CONNECTION
~	DIODE
⊞	FUSE
SPK	SPEAKER
SW	SWITCH
DS	DUAL SWITCH
RH	RHEOSTAT
LED	LED
J	JUMPER
GR	GROUND
CON	CONNECTOR
2W	2 WIRE LIGHT
3W	3 WIRE LIGHT

PRECISIONWORKS MANUFACTURING 120 8TH AVE LONGMONT, CO 80501		TITLE: Harness	
THIS DRAWING IS THE PROPERTY OF PRECISIONWORKS MANUFACTURING AND IS NOT TO BE DUPLICATED OR USED IN ANY WAY DETRIMENTAL TO THEIR BEST INTEREST.			
MATERIAL SPEC:	SCALE:	RELEASE NO:	DWG NO:
MODEL: Champion	NTS	DATE: 11/27/2013	24400-RevB

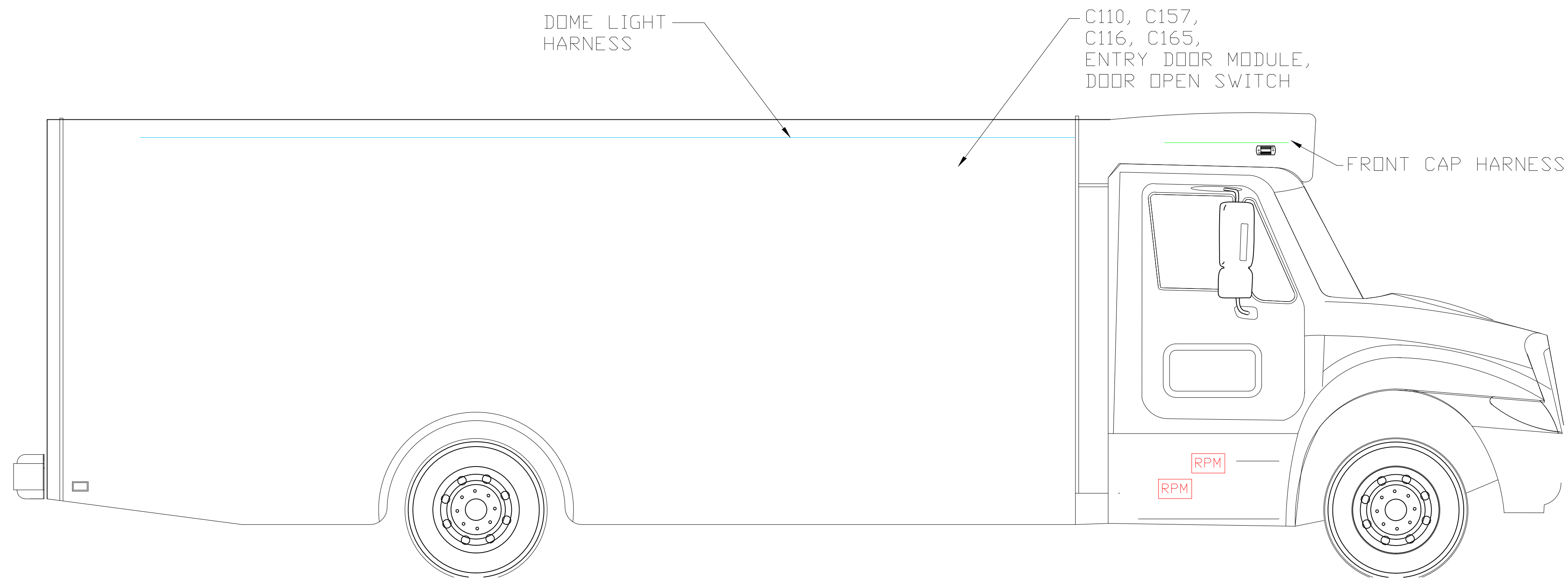

REV.	BY	DATE	DESCRIPTION	RELEASE #
C	PW	8/1/13	UPDATED MISC TO HARNESS PRINTS	
B	PW	7/21/08	UPDATED MISC TO HARNESS PRINTS	
A	PW	5/5/09	UPDATED ADDON CARDS	

COLOR CODES	
B	BLUE
E	GREY
G	GREEN
K	BLACK
I	PINK
N	BROWN
O	ORANGE
P	PURPLE
R	RED
T	TAN
Y	YELLOW
W	WHITE

LEGEND	
—	CONNECTION
—	NO CONNECTION
—	DIODE
—	FUSE
—	SPEAKER
—	SWITCH
—	DUAL SWITCH
—	RHEOSTAT
—	LED
—	JUMPER
—	GROUND
—	CONNECTOR
—	2 WIRE LIGHT
—	3 WIRE LIGHT

PRECISIONWORKS MANUFACTURING 120 9TH AVE. E-4 LONGMONT, CO 80501		TITLE: Entry_DR_Harness	
THIS DRAWING IS THE PROPERTY OF PRECISIONWORKS MANUFACTURING AND IS NOT TO BE DUPLICATED OR USED IN ANY WAY DETRIMENTAL TO THEIR BEST INTEREST.		ADDITIONAL INFO:	
MATERIAL SPEC:		SCALE: NTS	RELEASE NO. DWG NO. 24400-RevB
MODEL: Champion		DATE: 11/27/2013	SHEET:

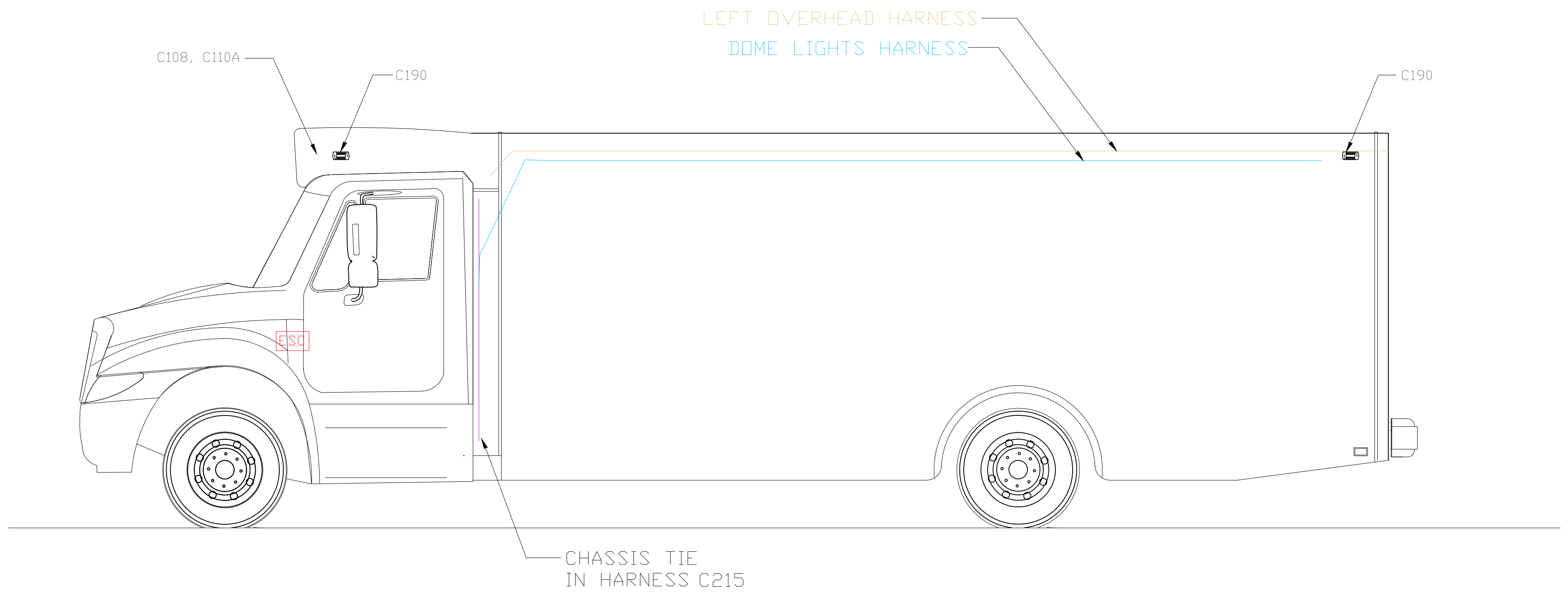

REV	BY	DATE	DESCRIPTION	RELEASE #
C	PW	8/1/13	UPDATED MISC TO HARNESS PRINTS	
B	PW	7/21/08	UPDATED MISC TO HARNESS PRINTS	
A	PW	5/5/08	UPDATED ADDON CARDS	

COLOR CODES	
B	BLUE
E	GREY
G	GREEN
K	BLACK
I	PINK
N	BROWN
O	ORANGE
P	PURPLE
R	RED
T	TAN
Y	YELLOW
W	WHITE

LEGEND	
○	CONNECTION
○	NO CONNECTION
⬮	DIODE
⊞	FUSE
⊞	SPEAKER
⊞	SWITCH
⊞	DUAL SWITCH
⊞	RHEOSTAT
⊞	LED
⊞	JUMPER
⊞	GROUND
⊞	CONNECTOR
⊞	2 WIRE LIGHT
⊞	3 WIRE LIGHT

PRECISIONWORKS MANUFACTURING <small>100 20TH AVE E LONGMONT, CO 80501</small>		TITLE: Heater_harness	
<small>THIS DRAWING IS THE PROPERTY OF PRECISIONWORKS MANUFACTURING AND IS NOT TO BE DUPLICATED OR USED IN ANY WAY DETRIMENTAL TO THEIR BEST INTERESTS.</small>			
MATERIAL SPEC: Champion		SIZE: C SCALE: NTS	RELEASE NO: 24400-RevB DATE: 11/27/2013 SHEET:

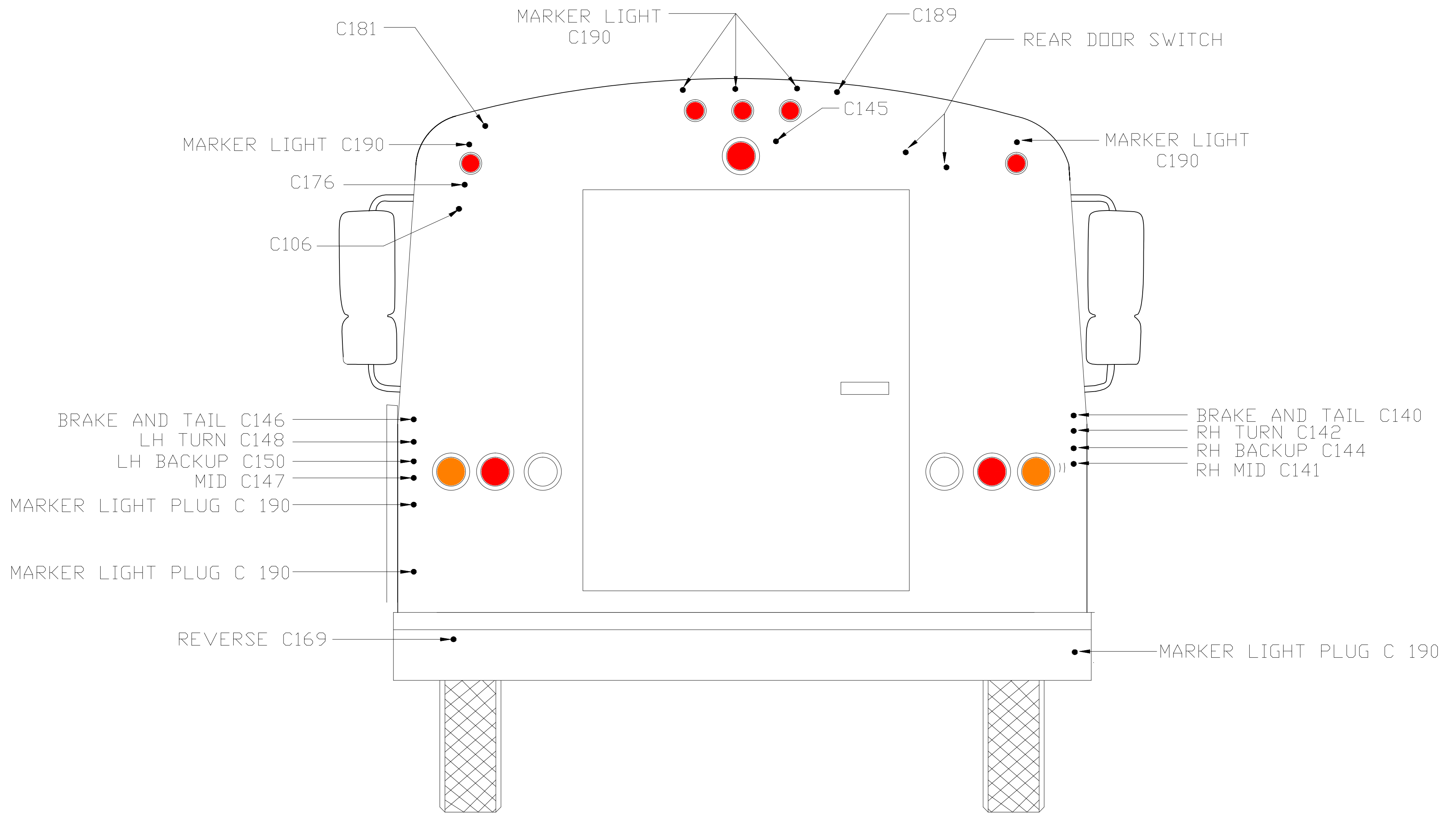

REV.	BY	DATE	DESCRIPTION	RELEASE #
C	PW	8/7/13	UPDATED MSC TO HARNESS PRINTS	
B	PW	7/21/08	UPDATED MSC TO HARNESS PRINTS	
A	PW	5/5/08	UPDATED ADDON CARDS	

COLOR CODES	
B	BLUE
E	GREY
G	GREEN
K	BLACK
I	PINK
N	BROWN
O	ORANGE
P	PURPLE
R	RED
T	TAN
Y	YELLOW
W	WHITE

LEGEND	
○	NO CONNECTION
○	NO CONNECTION
○	DIODE
○	FUSE
○	SPEAKER
○	SWITCH
○	DUAL SWITCH
○	RHEOSTAT
○	LED
○	JUMPER
○	GROUND
○	CONNECTOR
○	2 WIRE LIGHT
○	3 WIRE LIGHT

PRECISIONWORKS MANUFACTURING 120 37th Ave. E. 4 LONGMONT, CO 80501		TITLE: Rear_Lights	
THIS DRAWING IS THE PROPERTY OF PRECISIONWORKS MANUFACTURING AND IS NOT TO BE DUPLICATED OR USED IN ANY WAY DETRIMENTAL TO THEIR BEST INTEREST.		ADDITIONAL INFO:	
MATERIAL SPEC:	SCALE:	RELEASE NO.:	DWG NO.:
Model:	NTS	24400-RevB	
Champion		DATE:	SHEET:
		11/27/2013	

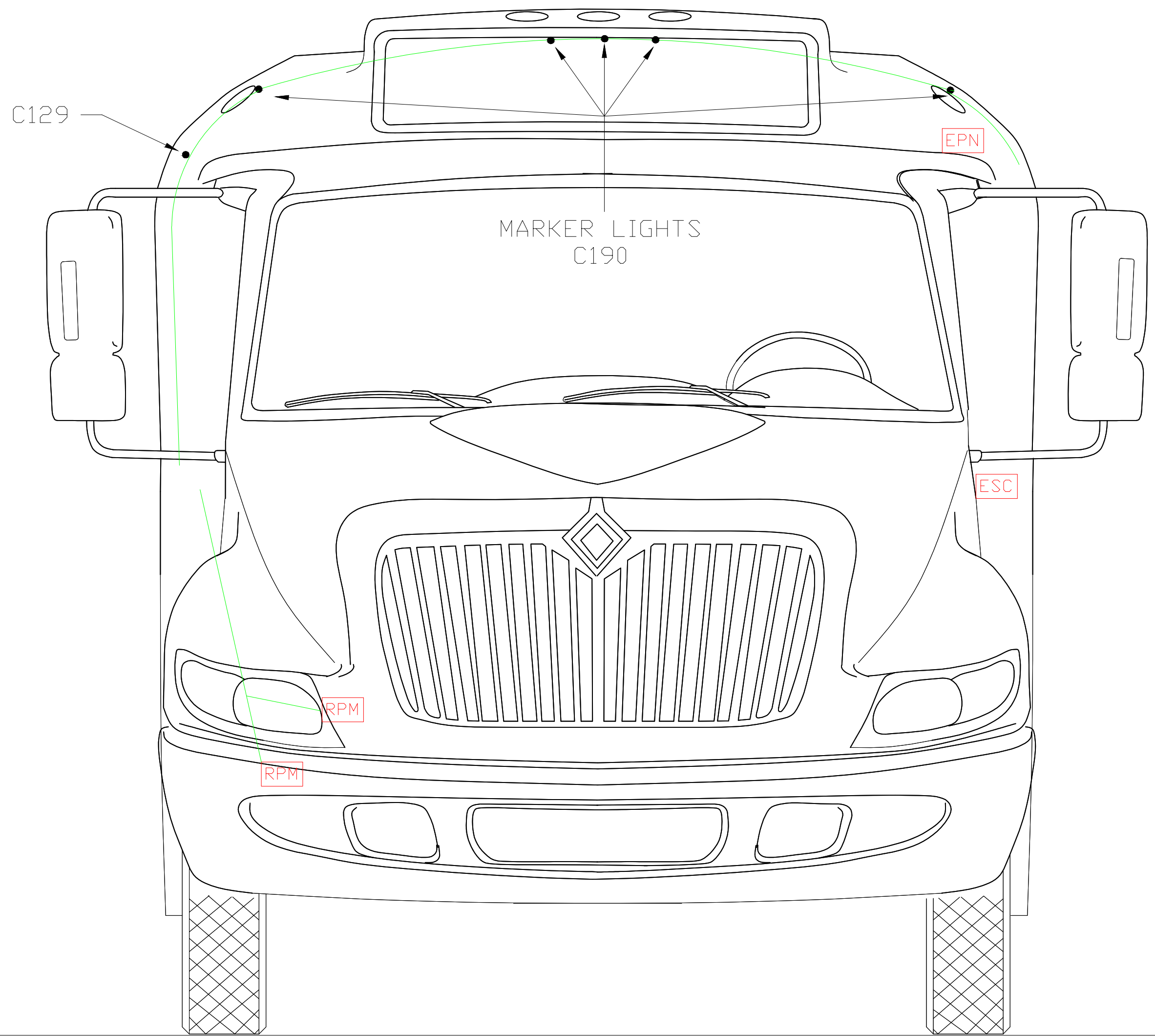

REV.	BY	DATE	DESCRIPTION	RELEASE #
C	PW	8/1/13	UPDATED MISC TO HARNESS PRINTS	
B	PW	7/21/08	UPDATED MISC TO HARNESS PRINTS	
A	PW	5/25/08	UPDATED ADDON CARDS	

COLOR CODES	
B	BLUE
E	GREY
G	GREEN
K	BLACK
I	PINK
N	BROWN
O	ORANGE
P	PURPLE
R	RED
T	TAN
Y	YELLOW
W	WHITE

LEGEND	
+	CONNECTION
-	NO CONNECTION
⊕	DIODE
⊖	FUSE
⊗	SPEAKER
⊘	SWITCH
⊕⊖	DUAL SWITCH
⊕⊖	RHEOSTAT
⊕	LED
⊕	JUMPER
⊕	GROUND
⊕	CONNECTOR
⊕	2 WIRE LIGHT
⊕	3 WIRE LIGHT

PRECISIONWORKS MANUFACTURING 120 0TH AVE E44 LONGMONT, CO 80501		TITLE: Front_Lights	
THIS DRAWING IS THE PROPERTY OF PRECISIONWORKS MANUFACTURING AND IS NOT TO BE DUPLICATED OR USED IN ANY WAY DETRIMENTAL TO THEIR BEST INTERESTS.		ADDITIONAL INFO:	
MATERIAL SPEC:		REV: C	RELEASE NO: 24400-RevB
MODEL: Champion	SCALE: NTS	DATE: 11/27/2013	SHEET: