

REV.	BY	DATE	DESCRIPTION	RELEASE #
C	PW	6/1/73	UPDATED WISC TO HARNESS PRINTS	
B	PW	7/21/78	UPDATED WISC TO HARNESS PRINTS	
A	PW	5/5/78	UPDATED ADDON CARDS	

COLOR CODES	
B	BLUE
G	GREEN
R	RED
Y	YELLOW
W	WHITE
P	PURPLE
N	BROWN
O	ORANGE
F	PINK
K	BLACK
L	LIGHT GREEN
C	CYAN
M	MAGENTA
U	UNIDENTIFIED

LEGEND	
○	CONNECTION
○	NO CONNECTION
○	DIODE
○	FUSE
○	SPEAKER
○	SWITCH
○	DUAL SWITCH
○	RHEOSTAT
○	JUMPER
○	GROUND
○	CONNECTOR
○	2 WIRE LIGHT
○	3 WIRE LIGHT

PRECISIONWORKS MANUFACTURING
 120 9TH AVE E-4
 LONDONONT, ON N6C 5R8

FILE: Front
 ADDITIONAL INFO:
 C: RELEASE NO. DWG NO. 24644
 SCALE: NTS DATE: 12/26/2013 SHEET: 1

MATERIAL SPEC: CHAMPION
 MODEL: 12/26/2013

F#	VALUE	FUNCTION	CONNECTOR
F1	15	BUZZER	J3,3
F2	15	STEP LIGHTS IGN	J4,1
F3	15	BACK UP CAMERA	J3,6
F4	NA	NOT USED	-179-J
F5	NA	NOT USED	J11,1
F6	15	AC IGNITION	J4,2
F7	15	HEATER SHUTOFF/PUMP	-177-E
F8	15	DOME/CENTER LIGHT	J11,2/J11,3/J61
F9	15	HEAT 1	-177-G
F10	15	F CLEARANCE/SWITCH	J1,2/J1,3/J9,1
F11	15	FLASHER/REAR DR BUZZ RLY	J3,5/-178-C
F12	15	RELAY POWER/CAMERA	J9,2/J10,2
F13	NA	NOT USED	J3,4
F14	15	DASH SWITCH IGN	J3,5
F15	15	EXIT LIGHT IGN	J4,4/J8,1
F16	NA	NOT USED	J7,1
F17	25	DOOR BATTERY	J2,1
F18	15	DOOR SWITCH, LIFT, LIFT LIGHTS	J1,1
F19	15	RADIO BATTERY/CAMERA	J2,2
F20		SPARE IGNITION	J3,2
F21		SPARE IGNITION	J3,1
F22		SPARE BATTERY	J2,3
F23		SPARE BATTERY	J2,4
F24		SPARE BATTERY	J2,5

REVISIONS			
REV.	BY	DATE	DESCRIPTION

PRECISIONWORKS MANUFACTURING 120 9TH AVE E-4 LONGMONT, CO 80501		TITLE: Electrical Panel Fuse Values	
THIS DRAWING IS THE PROPERTY OF PRECISIONWORKS MANUFACTURING AND IS NOT TO BE DUPLICATED OR USED IN ANY WAY DETRIMENTAL TO THEIR BEST INTEREST.		ADDITIONAL INFO:	
MATERIAL SPEC:	SCALE:	RELEASE NO.:	DWG NO.:
C	NTS		24644
MODEL: Champion	SCALE:	DATE:	SHEET:
	NTS	12/26/2013	

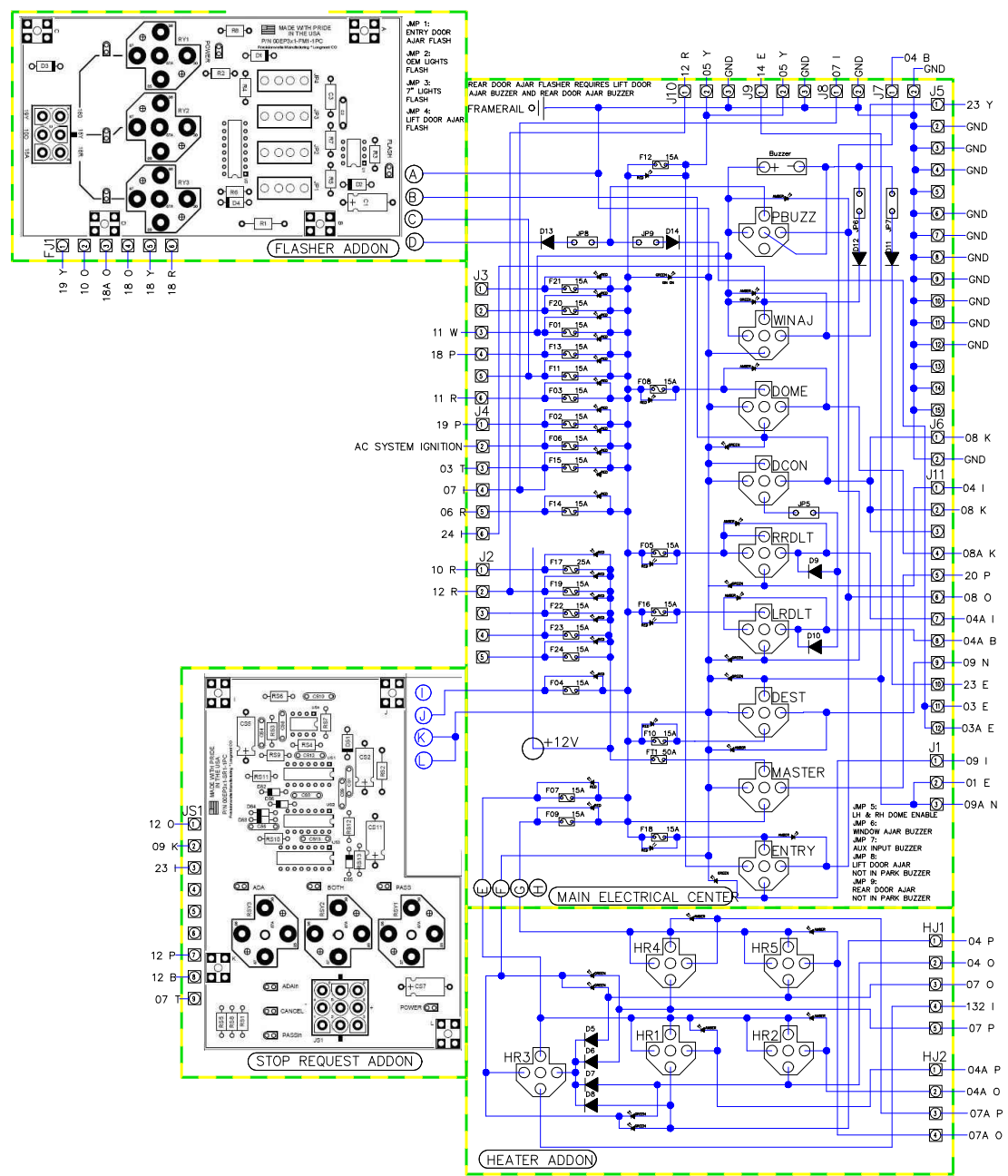

REV.	BY	DATE	DESCRIPTION	RELEASE #
C	FW	6/7/13	UPDATED MSG TO HARNESS PRINTS	
B	FW	7/21/13	UPDATED MSG TO HARNESS PRINTS	
A	FW	5/5/09	UPDATED ADDON CARDS	

COLOR CODES	
B	BLUE
E	GREY
G	GREEN
K	BLACK
I	PINK
N	BROWN
O	ORANGE
P	PURPLE
R	RED
T	TAN
Y	YELLOW
W	WHITE

LEGEND	
—○—	CONNECTION
---	NO CONNECTION
— —	DIODE
—F—	FUSE
—S—	SPEAKER
—SW—	SWITCH
—DSW—	DUAL SWITCH
—R—	RHEOSTAT
—L—	LED
—J—	JUMPER
—G—	GROUND
—C—	CONNECTOR
—2—	2 WIRE LIGHT
—3—	3 WIRE LIGHT

PRECISIONWORKS MANUFACTURING 120 8TH AVE. E. LONGMONT, CO 80501		TITLE: EP3_Panel	
THIS DRAWING IS THE PROPERTY OF PRECISIONWORKS MANUFACTURING AND IS NOT TO BE DUPLICATED OR USED IN ANY WAY DETRIMENTAL TO THEIR BEST INTEREST.		ADDITIONAL INFO:	
MATERIAL SPEC:	SCALE:	RELEASE NO.:	DWG. NO.:
Champion	NTS	12/26/2013	24644
		DATE:	SHEET:
		12/26/2013	3

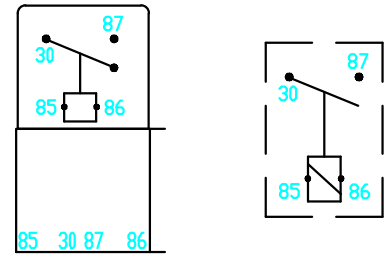

12 VOLT RELAY

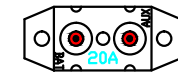

POST BREAKER

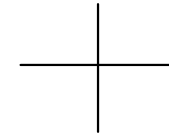

WIRE NOT CONNECTED



GROUND LOCATION

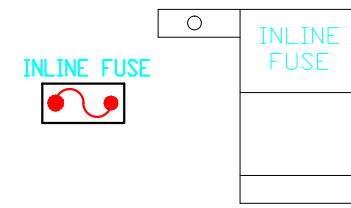

INLINE FUSE



GROUND INPUT

POWER STUD

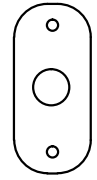

POWER STUD

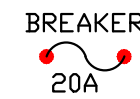

BREAKER



CONNECTION POINT



DIODE

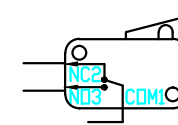

MICRO SWITCH

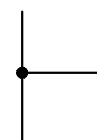

WIRE CONNECTED



BATTERY DISCONNECT

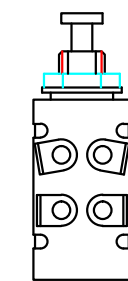

DPST JAMB SWITCH

WIRE COLOR CODES

COLOR CODES			
B	BLUE	O	ORANGE
E	GREY	P	PURPLE
G	GREEN	R	RED
K	BLACK	T	TAN
I	PINK	Y	YELLOW
N	BROWN	W	WHITE

COLOR CODES			
B	BLUE	O	ORANGE
E	GREY	P	PURPLE
G	GREEN	R	RED
K	BLACK	T	TAN
I	PINK	Y	YELLOW
N	BROWN	W	WHITE

LEGEND	
	CONNECTION
	NO CONNECTION
	DIODE
	FUSE
	SPEAKER
	SWITCH
	DUAL SWITCH
	RHEOSTAT
	LED
	JUMPER
	GROUND
	CONNECTOR
	2 WIRE LIGHT
	3 WIRE LIGHT

REVISIONS			
REV.	BY	DATE	RELEASE #

PRECISIONWORKS MANUFACTURING 120 9TH AVE E-4 LONGMONT, CO 80501		TITLE: Legend 1	
THIS DRAWING IS THE PROPERTY OF PRECISIONWORKS MANUFACTURING AND IS NOT TO BE DUPLICATED OR USED IN ANY WAY DETRIMENTAL TO THEIR BEST INTEREST.		ADDITIONAL INFO:	
MATERIAL SPEC:	SCALE: C	RELEASE NO.:	DWG NO. 24644
MODEL: Champion	DATE: 12/26/2013	SHEET	

A-CW/D-CW

C193-P 1 20P IGNITION TRG

FEMALE CONNECTOR 12010973
CBI #39-7185-5
MALE TERMINAL 12124582-L
CBI #39-7096-9
SEAL 12015323-V
CBI #39-7098-5

B	GND	GROUND
A	090	ENTRY LIGHTS

BLUNT CUT WIRE



C113

1	GND	GROUND
2	09W	DOOR CLOSE
3	09Y	DOOR OPEN
4	10R	DOOR POWER

C161

1		NOT USED
2	18W	REVERSE LIGHTS
3	18Y	LEFT TURN
4	09N	MARKER LIGHTS
5	18R	RIGHT TURN
6	09B	BRAKE LIGHTS

C215

1		NOT USED
2	18W	REVERSE LIGHTS
3	18Y	LEFT TURN
4	09N	MARKER LIGHTS
5	18R	RIGHT TURN
6	09B	BRAKE LIGHTS

PLUG CONNECTOR
AMP 1-480702-0
CBI #39-7154-0
SOCKET TERMINALS 350550-1
CBI #39-7155-3

CAP CONNECTOR
AMP 1-480705-0
CBI #39-7154-5
SOCKET TERMINALS 350550-1
CBI #39-7155-3

PLUG CONNECTOR
AMP 1-480704-0
CBI #39-7154-1
SOCKET TERMINALS 350550-1
CBI #39-7155-3

L 915-QE

19P	DOOR OPEN SIG
GND	GROUND

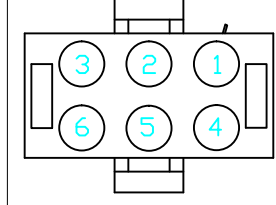
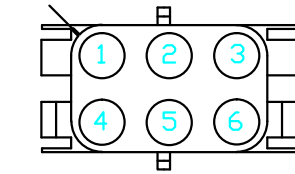

SPEAKER TERMINAL
MOLEX TERM. TAPE
QV-DIS FEM F/INS 16-1423
CBI #39-4426-1

L 906

100	LIFT DOOR AJAR
08T	LIFT LIGHTS

L 909-13

1	07I	EXIT LIGHTS
2	GND	GROUND

PLUG CONNECTOR
AMP 1-480698-0
CBI #39-7153-9
SOCKET TERMINALS 350550-1
CBI #39-7155-3



SPEAKER TERMINAL
MOLEX TERM. TAPE
QV-DIS FEM F/INS 16-1423
CBI #39-4426-1

C128

A	08T	LIFT LIGHTS
B	GND	GROUND

C169

18W	REVERSE LIGHTS
GND	GROUND



FEMALE CONNECTOR 12010973
CBI #39-7185-5
MALE TERMINAL 12124582-L
CBI #39-7096-9
SEAL 12015323-V
CBI #39-7098-5



C137

1	11R	RADIO IGN
2	12R	RADIO MEM
3	GND	GROUND
4		NOT USED
5	28W	LF SPKR +
6	28W/K	LF SPKR -
7	28E	RF SPKR +
8	28E/K	RF SPKR -
9	28P	RR SPKR +
10	28P/K	RR SPKR -
11	28G	LR SPKR +
12	28G/K	LR SPKR -

PLUG CONNECTOR
AMP 1-480708-0
CBI #39-7154-7
TERMINALS 350550-1
CBI #39-7155-3

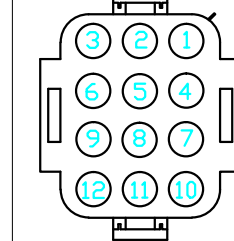

COLOR CODES

B	BLUE
E	GREY
G	GREEN
K	BLACK
J	PINK
N	BROWN
O	ORANGE
P	PURPLE
R	RED
T	TAN
Y	YELLOW
W	WHITE

LEGEND

○	CONNECTION
○	NO CONNECTION
△	DIODE
⊥	FUSE
⊥	SPEAKER
⊥	SWITCH
⊥	DUAL SWITCH
⊥	RHEOSTAT
⊥	LED
⊥	JUMPER
⊥	GROUND
⊥	CONNECTOR
⊥	2 WIRE LIGHT
⊥	3 WIRE LIGHT

REVISIONS

REV.	BY	DATE	DESCRIPTION	RELEASE #

PRECISIONWORKS MANUFACTURING 120 9TH AVE E-4 LONGMONT, CO 80501		TITLE: Legend 2	
THIS DRAWING IS THE PROPERTY OF PRECISIONWORKS MANUFACTURING AND IS NOT TO BE DUPLICATED OR USED IN ANY WAY DETRIMENTAL TO THEIR BEST INTEREST.		ADDITIONAL INFO:	
MATERIAL SPEC:	SIZE: C	RELEASE NO.:	DWG NO. 24644
MODEL: Champion	SCALE: NTS	DATE: 12/26/2013	SHEET 5 of 23

C147-PW	A	09N	MARKER LIGHT
	B	18Y	LH TURN SIGNAL
	C	GND	GROUND

MALE CONNECTOR 12020829
CBI #39-7214-5
MALE TERMINAL 12124582-L
CBI #39-7096-9
SEAL 12015323-V
CBI #39-7098-5

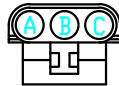

C187-P	1	10B	LIFT POWER
	2	R	NOT USED
	3	06Y	GATEWAY PWR
	4	100	LIFT DOOR

PLUG CONNECTOR
AMP 1-480702-0
CBI #39-7154-0
SOCKET TERMINALS 350550-1
CBI #39-7155-3



C189	1	07I	EXIT LIGHTS
	2	GND	GROUND

CAP CONNECTOR
AMP 1-480699-0
CBI #39-7154-3
PIN TERMINALS 350547-1
CBI #39-7155-2



C153	1	09N	MARKER LIGHT
	2	GND	GROUND

CAP CONNECTOR
AMP 1-480699-0
CBI #39-7154-3
PIN TERMINALS 350547-1
CBI #39-7155-2

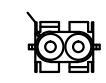

C140-P	1	09N	MARKER LIGHT
	2	09B	BRAKE LIGHT
	3	GND	GROUND

PLUG CONNECTOR
AMP 1-480700-0
CBI #B13-1914
PIN TERMINALS 350547-1
CBI #39-7155-2



C146-P	1	09N	MARKER LIGHT
	2	09B	BRAKE LIGHT
	3	GND	GROUND

PLUG CONNECTOR
AMP 1-480700-0
CBI #B13-1914
PIN TERMINALS 350547-1
CBI #39-7155-2



C144-P	1	18W	REVERSE SIGNAL
	2	GND	GROUND

PLUG CONNECTOR
AMP 1-480698-0
CBI #39-7153-9
PIN TERMINALS 350547-1
CBI #39-7155-2



C142-P	1	18R	RH TURN SIGNAL
	2	GND	GROUND

PLUG CONNECTOR
AMP 1-480698-0
CBI #39-7153-9
PIN TERMINALS 350547-1
CBI #39-7155-2



C141-PW	A	09N	MARKER LIGHT
	B	18R	RH TURN SIGNAL
	C	GND	GROUND

MALE CONNECTOR 12020829
CBI #39-7214-5
MALE TERMINAL 12124582-L
CBI #39-7096-9
SEAL 12015323-V
CBI #39-7098-5

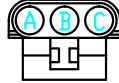

C103-C	1	02P	AUX POWER
	2	18W	REVERSE SIGNAL
	3	GND	GROUND
	4	09N	MARKER LIGHTS
	5		NOT USED
	6	18R	RIGHT TURN SIG
	7	03T	REAR LUGG. LT
	8	GND	GROUND
	9	09B	BRAKE LIGHTS
	10	23Y	WINDOW AJAR
	11	18Y	LEFT TURN SIG
	12	07I	EXIT LIGHTS
	13		NOT USED
	14	180	7" LIGHT
	15	03E	REAR DOOR AJAR

CAP CONNECTOR
AMP 1-480711-0
CBI #39-7155-1
TER. 350547-1
CBI #39-7155-2

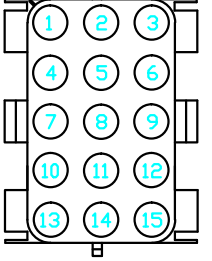

C103-P	1	02P	AUX POWER
	2	18W	BUZZER ALARM
	3	GND	GROUND
	4	09N	MARKER LIGHTS
	5		NOT USED
	6	18R	RIGHT TURN SIG
	7	03T	REAR LUGG. LT
	8	GND	GROUND
	9	09B	BRAKE LIGHTS
	10	23Y	WINDOW AJAR
	11	18Y	LEFT TURN SIG
	12	07I	EXIT LIGHTS
	13		NOT USED
	14	180	7" LIGHT
	15	03E	REAR DOOR AJAR

PLUG CONNECTOR
AMP 1-480710-0
CBI #39-7154-8
TER 350550-1
CBI #39-7155-3

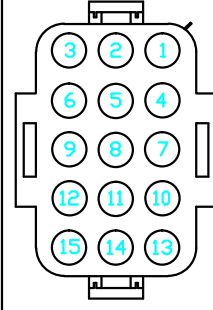

C068F	03AE	REAR DOOR AJAR
-------	------	----------------

SPEAKER TERMINAL
MOLEX TERM. TAPE
QV-DIS FEM F/INS 16-1423
CBI #39-4426-1



COLOR CODES	
B	BLUE
E	GREY
G	GREEN
K	BLACK
J	PINK
N	BROWN
O	ORANGE
P	PURPLE
R	RED
T	TAN
Y	YELLOW
W	WHITE

LEGEND	
○	CONNECTION
○	NO CONNECTION
⏏	DIODE
⏏	FUSE
⏏	SPEAKER
⏏	SWITCH
⏏	DUAL SWITCH
⏏	RHEOSTAT
⏏	LED
⏏	JUMPER
⏏	GROUND
⏏	CONNECTOR
⏏	2 WIRE LIGHT
⏏	3 WIRE LIGHT

REVISIONS			
REV.	BY	DATE	DESCRIPTION
C	PW	8/1/13	UPDATED MISC TO HARNESS PRINTS
B	PW	7/21/08	UPDATED MISC TO HARNESS PRINTS
A	PW	5/5/08	UPDATED ADDON CARDS

PRECISIONWORKS MANUFACTURING 120 9TH AVE E-4 LONGMONT, CO 80501		TITLE: Legend 3	
THIS DRAWING IS THE PROPERTY OF PRECISIONWORKS MANUFACTURING AND IS NOT TO BE DUPLICATED OR USED IN ANY WAY DETRIMENTAL TO THEIR BEST INTEREST.		ADDITIONAL INFO:	
MATERIAL SPEC:	SCALE:	RELEASE NO.:	DWG NO.:
Champion	NTS	12/26/2013	24644
		DATE:	SHEET
		12/26/2013	6 OF 23

C148-P	1	18Y	LH TURN SIGNAL
	2	GND	GROUND

PLUG CONNECTOR
AMP 1-480698-0
CBI #39-7153-9
PIN TERMINALS 350547-1
CBI #39-7155-2



C117-C	1	08K	DOME LIGHTS
	2	GND	GROUND

CAP CONNECTOR
AMP 1-480699-0
CBI #39-7154-3
PIN TERMINALS 350547-1
CBI #39-7155-2



C116-C	1	09W	DOOR CLOSE
	2	GND	GROUND
	3	09Y	DOOR OPEN
	4	10R	DOOR BATT PWR

CAP CONNECTOR
AMP 1-480703-0
CBI #39-7154-4
PIN TERMINALS 350547-1
CBI #39-7155-2

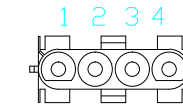

C150-P	1	18W	LH REVERSE LT
	2	GND	GROUND

PLUG CONNECTOR
AMP 1-480698-0
CBI #39-7153-9
PIN TERMINALS 350547-1
CBI #39-7155-2



C108-C	1	04P	HEATER #2 HIGH
	2		
	3	04Q	HEATER #2 LOW
	4	GND	HEATER GROUND

CAP CONNECTOR
AMP 1-480703-0
CBI #39-7154-4
PIN TERMINALS 350547-1
CBI #39-7155-2

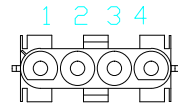

C110-C	1	08K	DOME LIGHTS
	2	GND	GROUND

CAP CONNECTOR
AMP 1-480699-0
CBI #39-7154-3
PIN TERMINALS 350547-1
CBI #39-7155-2



C165-C	1	GND	GROUND
	2	09Q	ENTRY LIGHTS

CAP CONNECTOR
AMP 1-480699-0
CBI #39-7154-3
PIN TERMINALS 350547-1
CBI #39-7155-2



C190E/F-C	A	09N	MARKER LIGHTS
	B	GND	GROUND

FEMALE CONNECTOR 12010973
CBI #39-7185-5
MALE TERMINAL 12124582-L
CBI #39-7096-9
SEAL 12015323-V
CBI #39-7098-5

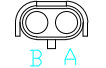

C108A-P	1	04P	HEATER #2 HIGH
	2		
	3	04Q	HEATER #2 LOW
	4	GND	HEATER GROUND

PLUG CONNECTOR
AMP 1-480702-0
CBI #39-7154-0
SOCKET TERMINALS 350550-1
CBI #39-7155-3



C110-P	1	08K	DOME LIGHTS
	2	GND	GROUND

PLUG CONNECTOR
AMP 1-480698-0
CBI #39-7153-9
SOCKET TERMINALS 350550-1
CBI #39-7155-3

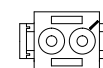

C165-P	1	GND	GROUND
	2	09Q	ENTRY LIGHTS

PLUG CONNECTOR
AMP 1-480698-0
CBI #39-7153-9
SOCKET TERMINALS 350550-1
CBI #39-7155-3



C190-C	1	09N	MARKER LIGHTS
	2	GND	GROUND

CAP CONNECTOR
AMP 1-480699-0
CBI #39-7154-3
PIN TERMINALS 350547-1
CBI #39-7155-2



C108-P	1	07P	HEATER #1 HIGH
	2		
	3	07Q	HEATER #1 LOW
	4	GND	HEATER GROUND

PLUG CONNECTOR
AMP 1-480702-0
CBI #39-7154-0
SOCKET TERMINALS 350550-1
CBI #39-7155-3



C157-C	1	07I	EXIT LIGHTS
	2	GND	GROUND

CAP CONNECTOR
AMP 1-480699-0
CBI #39-7154-3
PIN TERMINALS 350547-1
CBI #39-7155-2



C163B-P	1	08AI	LIFT LIGHTS
	2	10B	LIFT POWER
	3	GND	GROUND
	4	10D	LIFT DOOR AJAR

PLUG CONNECTOR
AMP 1-480702-0
CBI #39-7154-0
PIN TERMINALS 350547-1
CBI #39-7155-2



C145-P	1	09B	CEN. BRAKE LIGHT
	2	GND	GROUND

PLUG CONNECTOR
AMP 1-480698-0
CBI #39-7153-9
PIN TERMINALS 350547-1
CBI #39-7155-2

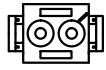

C109-C	1	09N	MARKER LIGHT
	2	GND	GROUND

CAP CONNECTOR
AMP 1-480699-0
CBI #39-7154-3
PIN TERMINALS 350547-1
CBI #39-7155-2



C106-C	1	02P	AUX POWER
	2	18W	REVERSE SIGNAL
	3	GND	GROUND
	4	09N	MARKER LIGHTS
	5		NOT USED
	6	18R	RIGHT TURN SIG
	7	03T	REAR LUGG. LT
	8	GND	GROUND
	9	09B	BRAKE LIGHTS
	10	23Y	WINDOW AJAR
	11	18Y	LEFT TURN SIG
	12	07I	EXIT LIGHTS
	13		NOT USED
	14	18Q	7" LIGHT
	15	03E	REAR DOOR AJAR

CAP CONNECTOR
AMP 1-480711-0
CBI #39-7155-1
TER. 350547-1
CBI #39-7155-2

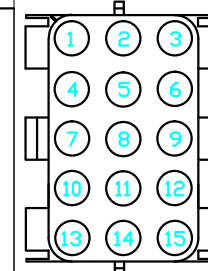

C106-P	1	02P	AUX POWER
	2	18W	BUZZER ALARM
	3	GND	GROUND
	4	09N	MARKER LIGHTS
	5		NOT USED
	6	18R	RIGHT TURN SIG
	7	03T	REAR LUGG. LT
	8	GND	GROUND
	9	09B	BRAKE LIGHTS
	10	23Y	WINDOW AJAR
	11	18Y	LEFT TURN SIG
	12	07I	EXIT LIGHTS
	13		NOT USED
	14	18Q	7" LIGHT
	15	03E	REAR DOOR AJAR

PLUG CONNECTOR
AMP 1-480710-0
CBI #39-7154-8
TER. 350550-1
CBI #39-7155-3

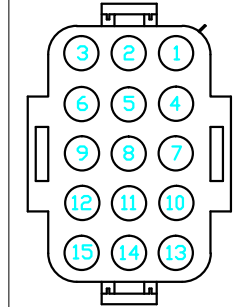

C129	28E	RT FRONT SPK
	28E/K	RT FRONT SPK

SPEAKER TERMINAL
MOLEX TERM. TAPE
QV-DIS FEM F/INS 16-1423
CBI #39-4426-1

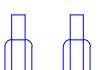

L907	08AI	LIFT LIGHTS
	GND	GROUND

SPEAKER TERMINAL
MOLEX TERM. TAPE
QV-DIS FEM F/INS 16-1423
CBI #39-4426-1



LEGEND

- CONNECTION
- NO CONNECTION
- △ DIODE
- FUSE
- ⊞ SPEAKER
- ⊞ SWITCH
- ⊞ DUAL SWITCH
- ⊞ RHEOSTAT
- ⊞ LED
- ⊞ JUMPER
- ⊞ GROUND
- ⊞ CONNECTOR
- ⊞ 2 WIRE LIGHT
- ⊞ 3 WIRE LIGHT

COLOR CODES

B	BLUE
E	GREY
G	GREEN
K	BLACK
I	PINK
N	BROWN
O	ORANGE
P	PURPLE
R	RED
T	TAN
Y	YELLOW
W	WHITE

REV.	BY	DATE	DESCRIPTION	RELEASE #

PRECISIONWORKS MANUFACTURING
120 9TH AVE E-4
LONGMONT, CO 80501

TITLE: Legend 4

ADDITIONAL INFO:

MATERIAL SPEC: C RELEASE NO. DWG NO. 24644

MODEL: Champion SCALE: NTS DATE: 12/26/2013 SHEET:

DOOR
ACTUATED
INTERIOR
LIGHTS

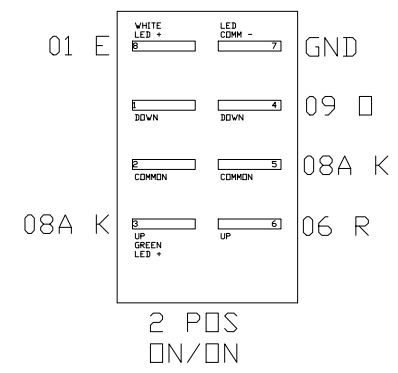

LIFT
MASTER

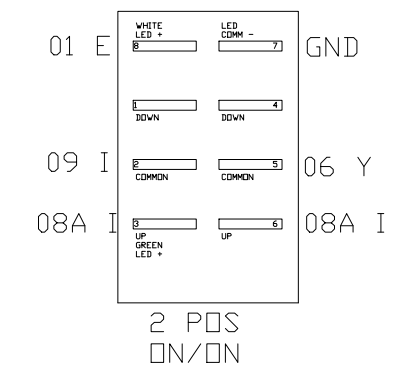

HEATER
1

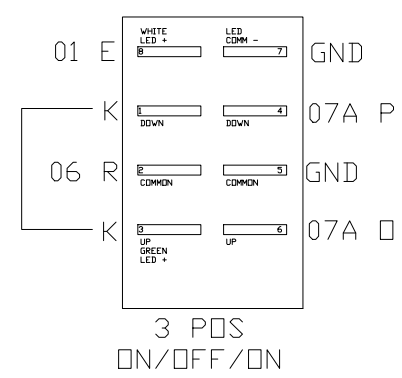

STEP
HEAT

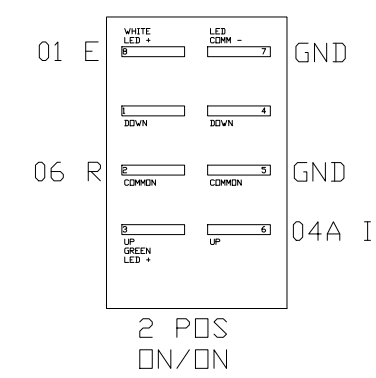

REAR
DOOR

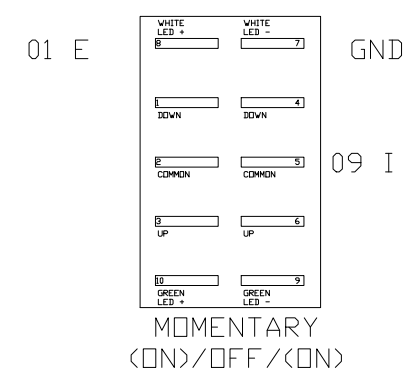

REV.	BY	DATE	DESCRIPTION	RELEASE #
C	FW	8/1/13	UPDATED MISC TO HARNESS PRINTS	
B	FW	7/21/09	UPDATED MISC TO HARNESS PRINTS	
A	FW	5/5/09	UPDATED ADDON CARDS	

COLOR CODES	
B	BLUE
E	GREY
G	GREEN
K	BLACK
I	PINK
N	BROWN
O	ORANGE
P	PURPLE
R	RED
T	TAN
Y	YELLOW
W	WHITE

LEGEND	
→	CONNECTION
---	NO CONNECTION
⊕	DIODE
⊞	FUSE
⊞	SPEAKER
⊞	SWITCH
⊞	DUAL SWITCH
⊞	RHEOSTAT
⊞	LED
⊞	JUMPER
⊞	GROUND
⊞	CONNECTOR
⊞	2 WIRE LIGHT
⊞	3 WIRE LIGHT

PRECISIONWORKS MANUFACTURING 100 9TH AVE. E-4 LONGMONT, CO 80501		TITLE: Switch_Wiring	
THIS DRAWING IS THE PROPERTY OF PRECISIONWORKS MANUFACTURING AND IS NOT TO BE DUPLICATED OR USED IN ANY MAY BE DETRIMENTAL TO THEIR BEST INTERESTS.		ADDITIONAL INFO:	
MATERIAL SPEC:	SCALE: NTS	RELEASE NO. C	DWG NO. 24644
MODEL: Champion	DATE: 12/26/2013	SHEET	

REVISIONS			
REV	BY	DATE	DESCRIPTION
C	FW	8/1/13	UPDATED MISC TO HARNESS PRINTS
B	FW	7/21/10	UPDATED MISC TO HARNESS PRINTS
A	FW	5/9/08	UPDATED ADDON CARDS

COLOR CODES	
B	BLUE
E	GREY
G	GREEN
K	BLACK
I	PINK
N	BROWN
O	ORANGE
P	PURPLE
R	RED
T	TAN
Y	YELLOW
W	WHITE

LEGEND	
—	CONNECTION
- - -	NO CONNECTION
⊕	DIODE
⊖	FUSE
SPK	SPEAKER
SW	SWITCH
DS	DUAL SWITCH
RH	RHEOSTAT
LED	LED
J	JUMPER
⊕	GROUND
⊖	CONNECTOR
—	2 WIRE LIGHT
—	3 WIRE LIGHT

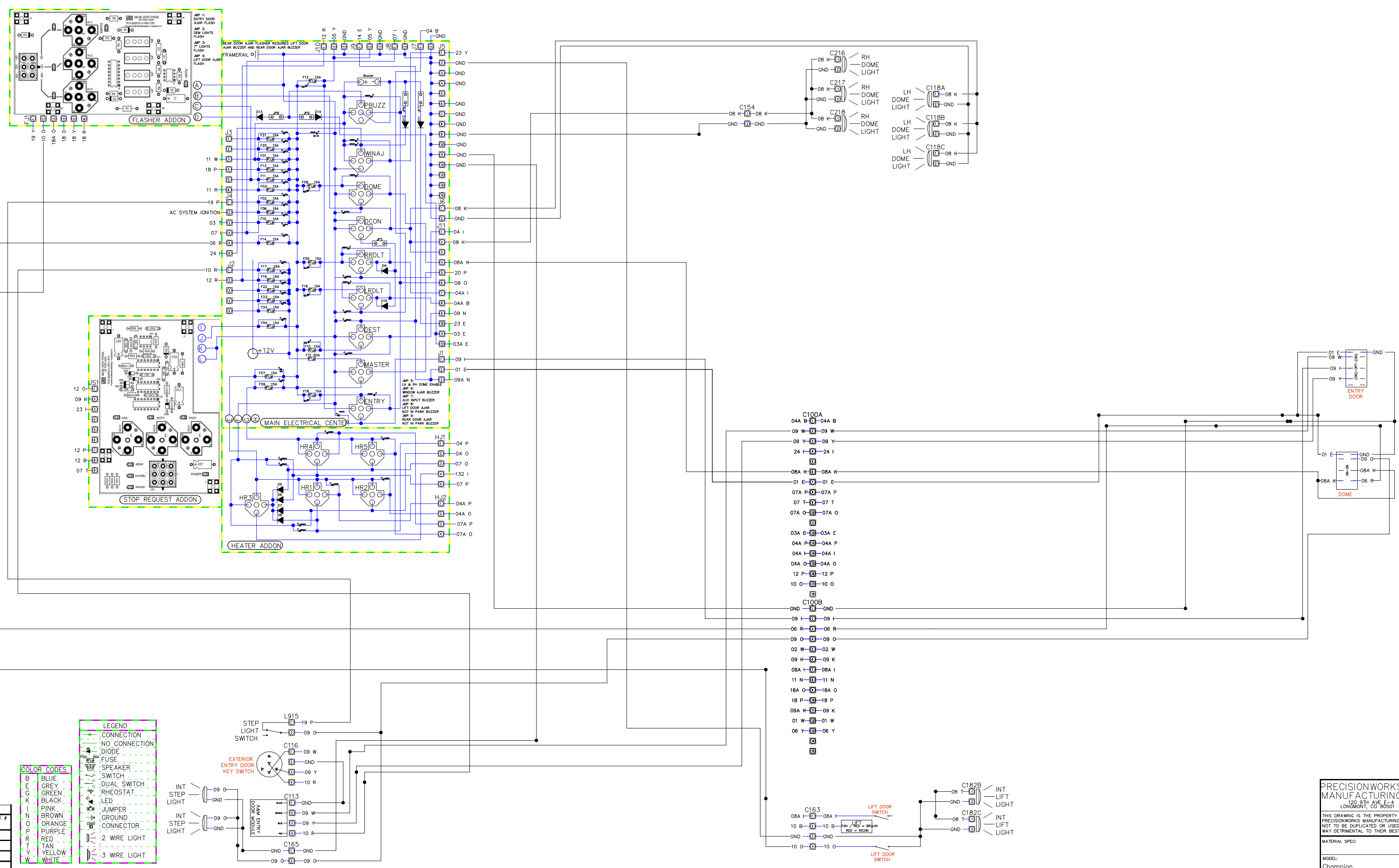

PRECISIONWORKS MANUFACTURING 120 8TH AVE S-4 LONGMONT, CO 80501		TITLE Interior_Lighting	
THIS DRAWING IS THE PROPERTY OF PRECISIONWORKS MANUFACTURING AND IS NOT TO BE REPRODUCED OR USED IN ANY WAY DETRIMENTAL TO THEIR BEST INTEREST.		ADDITIONAL INFO:	
MATERIAL SPEC:	SCALE	RELEASE NO.	DWG NO.
Champion	NTS	24644	24644
DATE	SHEET		
12/26/2013			

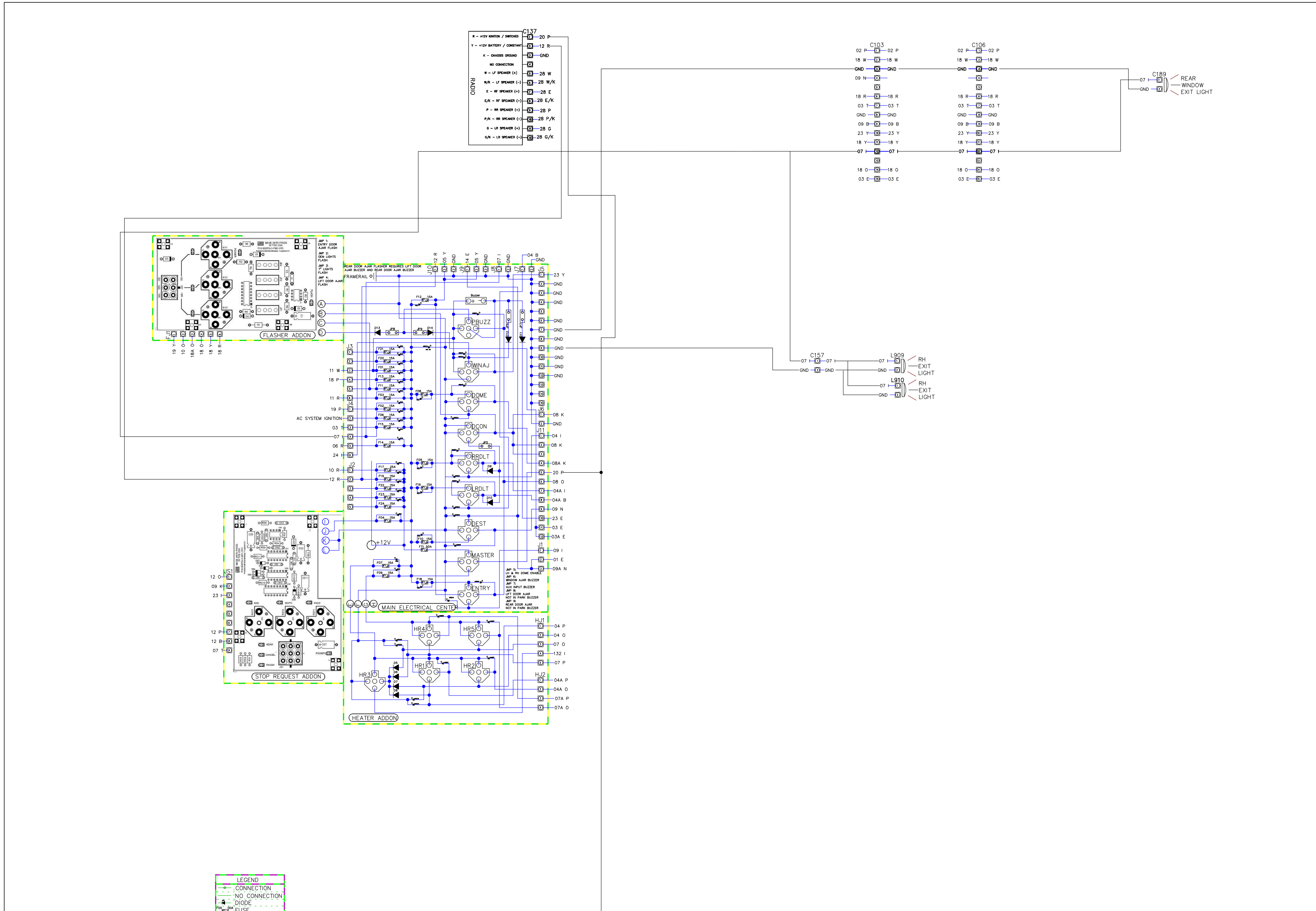

REVISIONS				
REV.	BY	DATE	DESCRIPTION	RELEASE #
C	PW	8/7/13	UPDATED MISC TO HARNESS PRINTS	
B	PW	7/21/08	UPDATED MISC TO HARNESS PRINTS	
A	PW	5/5/08	UPDATED ADDON CARDS	

COLOR CODES	
B	BLUE
C	GREEN
K	BLACK
L	PINK
N	BROWN
O	ORANGE
P	PURPLE
R	RED
T	TAN
Y	YELLOW
W	WHITE

LEGEND	
—	CONNECTION
- - -	NO CONNECTION
▲	DIODE
⊞	FUSE
⊞	SPEAKER
⊞	SWITCH
⊞	DUAL SWITCH
⊞	RHEOSTAT
⊞	LED
⊞	JUMPER
⊞	GROUND
⊞	CONNECTOR
⊞	2 WIRE LIGHT
⊞	3 WIRE LIGHT

PRECISIONWORKS MANUFACTURING 100 9TH AVE E-4 LONGMONT, CO 80501	TITLE: Ignition_Control_circuits
	ADDITIONAL INFO: <small>THIS DRAWING IS THE PROPERTY OF PRECISIONWORKS MANUFACTURING AND IS NOT TO BE DUPLICATED OR USED IN ANY WAY DETRIMENTAL TO THEIR BEST INTEREST.</small>
MATERIAL SPEC: C	RELEASE NO. DWG NO. C 24644
MODEL: Champion	SCALE DATE SHEET NTS 12/26/2013 1

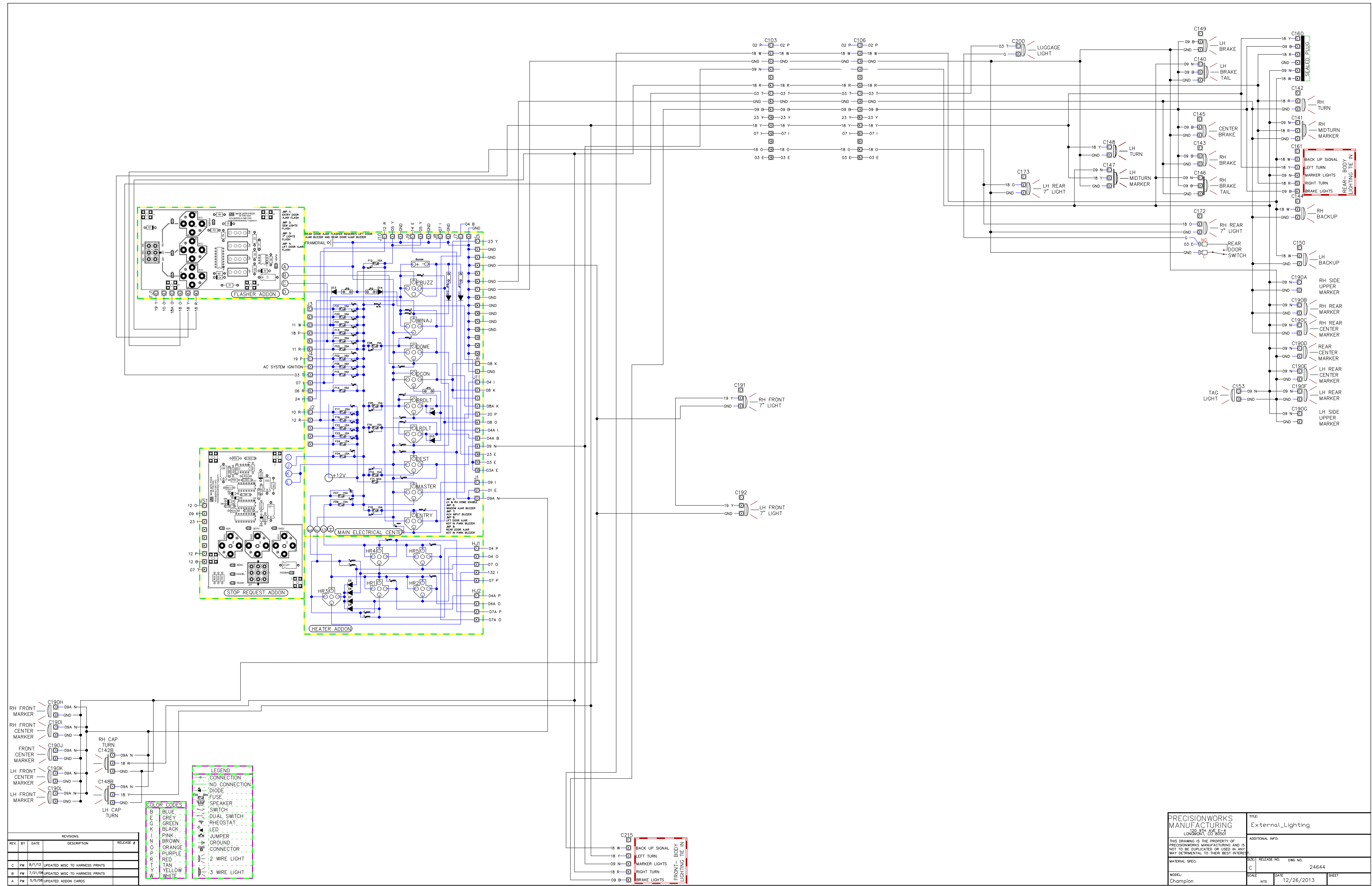

REV.	BY	DATE	DESCRIPTION	RELEASE #
C	PW	8/7/13	UPDATED MISC TO HARNESS PRINTS	
B	PW	7/21/09	UPDATED MISC TO HARNESS PRINTS	
A	PW	5/5/08	UPDATED ADDON CARDS	

LEGEND

- CONNECTION
- NO CONNECTION
- DIODE
- FUSE
- SPEAKER
- SWITCH
- DUAL SWITCH
- RHEOSTAT
- LED
- JUMPER
- GROUND
- CONNECTOR
- 2 WIRE LIGHT
- 3 WIRE LIGHT

COLOR CODES

- B BLUE
- C GREY
- G GREEN
- K BLACK
- I PINK
- N BROWN
- O ORANGE
- P PURPLE
- R RED
- T TAN
- Y YELLOW
- W WHITE

PRECISIONWORKS MANUFACTURING LONGMONT, CO 80501		TITLE External Lighting	
MATERIAL SPEC:		SCALE: NTS	
MODEL: Champion		DATE: 12/26/2013	
REVISIONS:		SHEET: 24644	
THIS DRAWING IS THE PROPERTY OF PRECISIONWORKS MANUFACTURING AND IS NOT TO BE DUPLICATED OR USED IN ANY WAY DETRIMENTAL TO THEIR BEST INTERESTS.		ADDITIONAL INFO:	
SIZE: C		DWG NO. 24644	

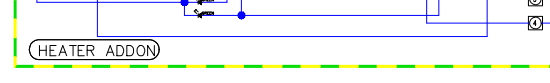
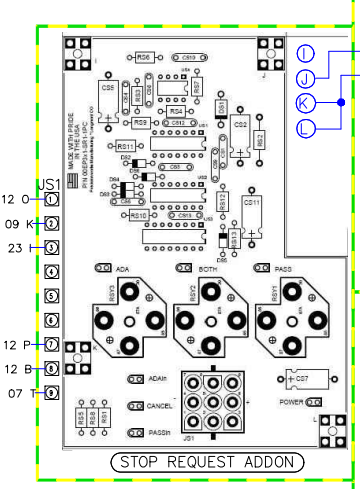
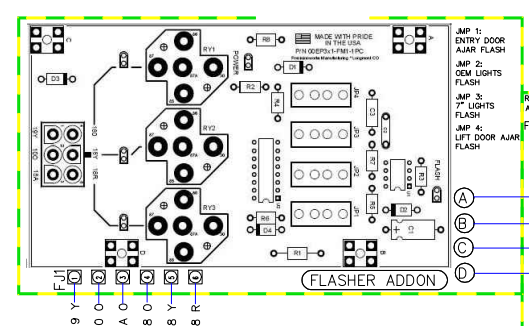
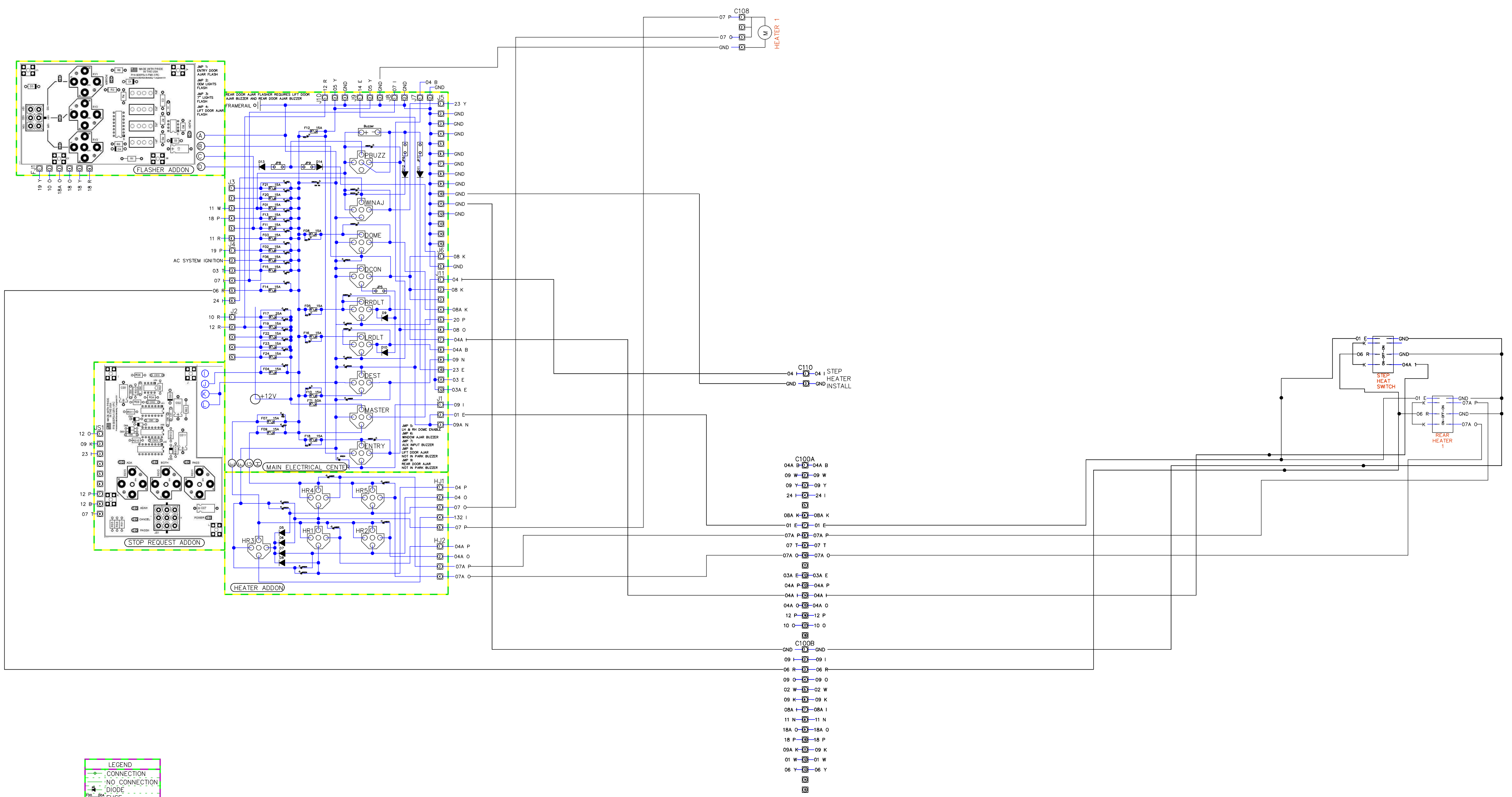

REV.	BY	DATE	DESCRIPTION	RELEASE #
C	FW	8/1/13	UPDATED MISC TO HARNESS PRINTS	
B	FW	7/21/08	UPDATED MISC TO HARNESS PRINTS	
A	FW	5/5/08	UPDATED ADDON CARDS	

COLOR CODES	
B	BLUE
E	GREY
G	GREEN
K	BLACK
L	PINK
N	BROWN
O	ORANGE
P	PURPLE
R	RED
T	TAN
Y	YELLOW
W	WHITE

LEGEND	
—○—	CONNECTION
—	NO CONNECTION
— —	DIODE
—F—	FUSE
—S—	SPEAKER
—S—	SWITCH
—DS—	DUAL SWITCH
—R—	RHEOSTAT
—L—	LED
—J—	JUMPER
—G—	GROUND
—C—	CONNECTOR
—2—	2 WIRE LIGHT
—3—	3 WIRE LIGHT

- C100A 04A B-04A B
- 09 W-09 W
- 09 Y-09 Y
- 24 I-24 I
- 08A K-08A K
- 01 E-01 E
- 07A P-07A P
- 07 T-07 T
- 07A O-07A O
- 03A E-03A E
- 04A P-04A P
- 04A I-04A I
- 04A O-04A O
- 12 P-12 P
- 10 O-10 O
- C100B 09 I-09 I
- 06 R-06 R
- 09 O-09 O
- 02 W-02 W
- 09 K-09 K
- 08A I-08A I
- 11 N-11 N
- 18A O-18A O
- 18 P-18 P
- 08A K-08A K
- 01 W-01 W
- 06 Y-06 Y

PRECISIONWORKS MANUFACTURING 1200 HWY. E-4 LONGMONT, CO 80501	TITLE Aux_Heating_System
	ADDITIONAL INFO: THIS DRAWING IS THE PROPERTY OF PRECISIONWORKS MANUFACTURING AND IS NOT TO BE DUPLICATED OR USED IN ANY WAY DETRIMENTAL TO THEIR BEST INTEREST.
MATERIAL SPEC:	SIZE: RELEASE NO. DWG NO. C 12/26/2013 24644
MODEL: Champion	SCALE: DATE SHEET NTS 12/26/2013

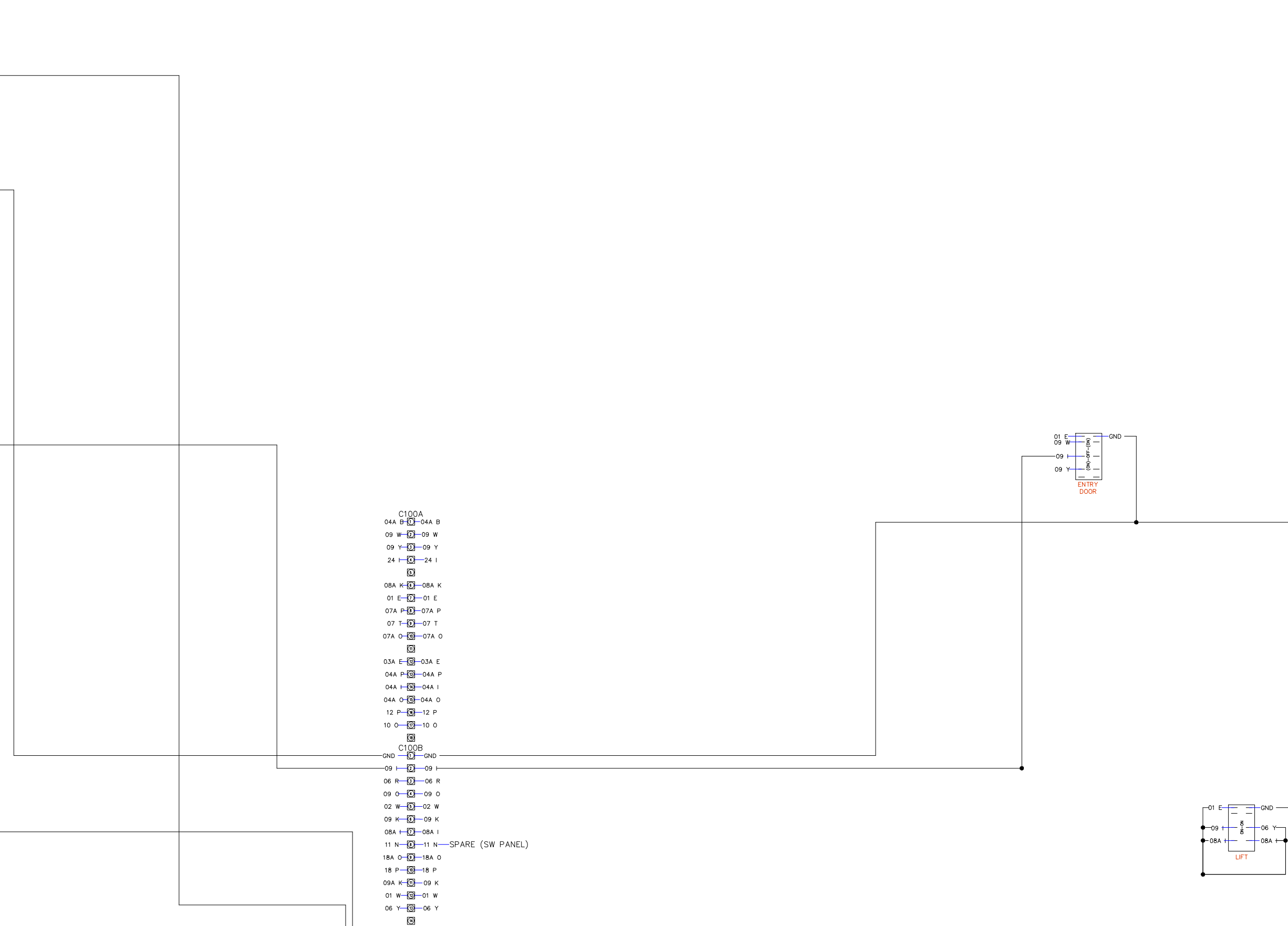
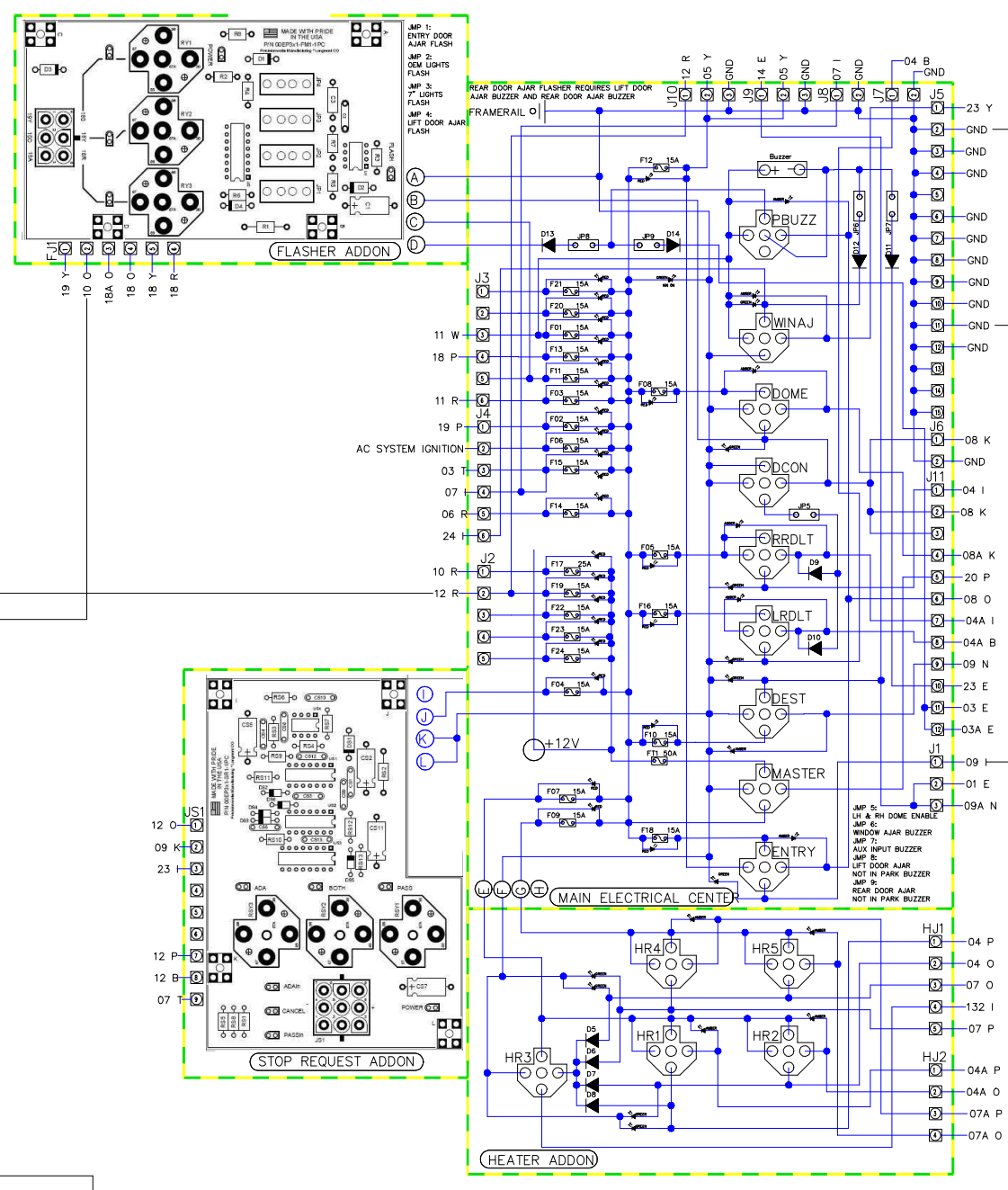

REVISIONS			
REV	BY	DATE	DESCRIPTION
C	FW	8/7/13	UPDATED MSC TO HARNESS PRINTS
B	FW	7/21/08	UPDATED MSC TO HARNESS PRINTS
A	FW	5/5/08	UPDATED ADDON CARDS

LEGEND	
	CONNECTION
	NO CONNECTION
	DIODE
	FUSE
	SPEAKER
	SWITCH
	DUAL SWITCH
	RHEOSTAT
	LED
	JUMPER
	GROUND
	CONNECTOR
	2 WIRE LIGHT
	3 WIRE LIGHT

COLOR CODES	
B	BLUE
E	GREY
G	GREEN
K	BLACK
I	PINK
N	BROWN
O	ORANGE
P	PURPLE
R	RED
T	TAN
Y	YELLOW
W	WHITE

PRECISIONWORKS MANUFACTURING		TITLE: Lift_System	
100 STEEL AVE. #4 LONGMONT, CO 80501		ADDITIONAL INFO:	
MATERIAL SPEC:		SIZE:	RELEASE NO. DWG NO.
MODEL: Champion		C	24644
SCALE: NTS		DATE:	SHEET:
		12/26/2013	

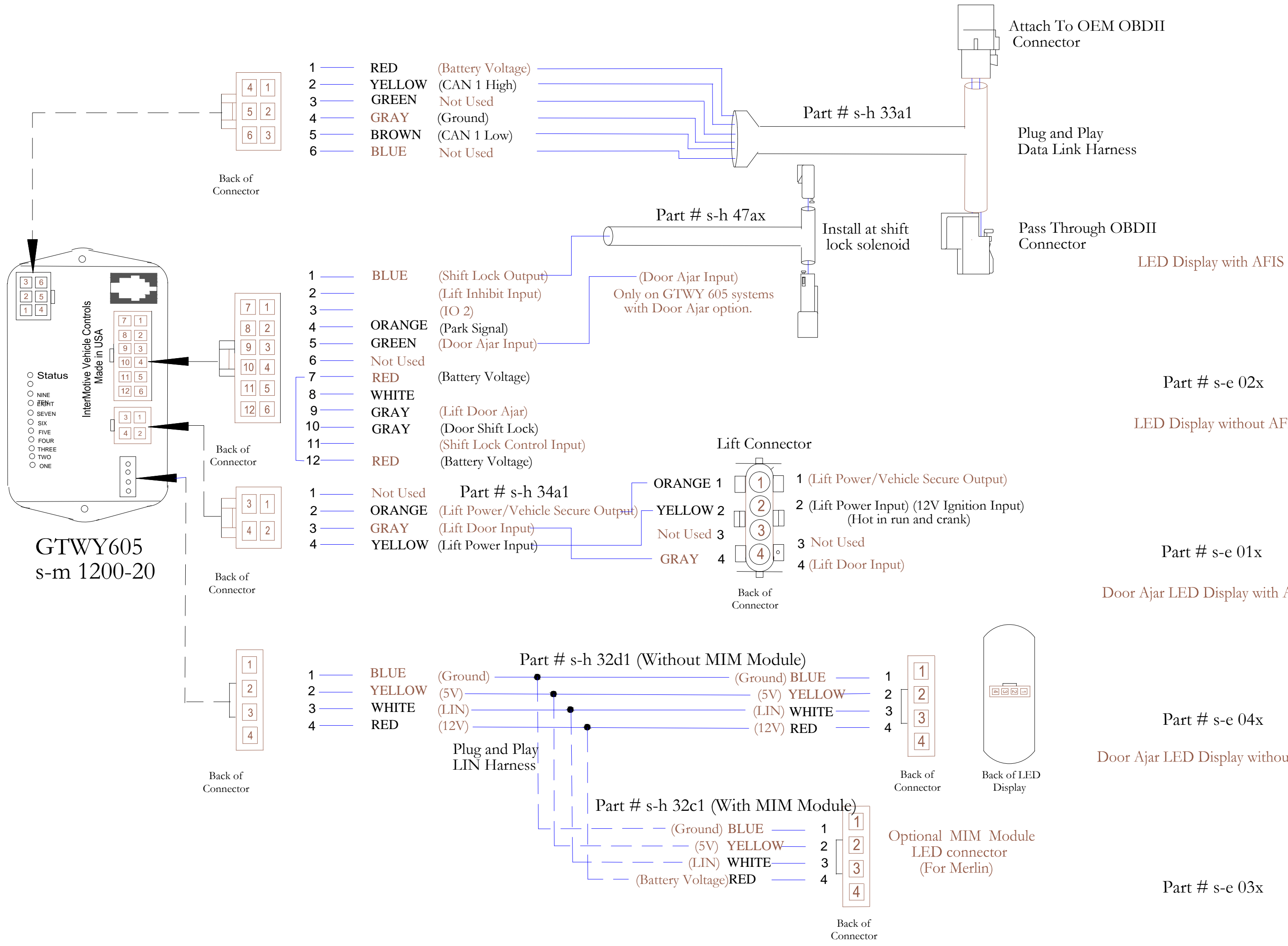

COLOR CODES		LEGEND	
B	BLUE	○	CONNECTION
E	GREY	○	NO CONNECTION
G	GREEN	⊗	DIODE
K	BLACK	⊕	FUSE
J	PINK	⊖	SPEAKER
N	BROWN	⊘	SWITCH
O	ORANGE	⊚	DUAL SWITCH
P	PURPLE	⊛	RHEOSTAT
R	RED	⊜	LED
T	TAN	⊝	JUMPER
Y	YELLOW	⊞	GROUND
W	WHITE	⊟	CONNECTOR
		⊠	2 WIRE LIGHT
		⊡	3 WIRE LIGHT

REVISIONS				
REV.	BY	DATE	DESCRIPTION	RELEASE #

LIFT SYSTEM

PRECISIONWORKS MANUFACTURING 20 9TH AVE E-4 LONGMONT, CO 80501		TITLE: Lift_page2	
MATERIAL SPEC:		SCALE: NTS	
MODEL: Champion		DATE: 12/26/2013	
THIS DRAWING IS THE PROPERTY OF PRECISIONWORKS MANUFACTURING AND IS NOT TO BE DUPLICATED OR USED IN ANY WAY DETRIMENTAL TO THEIR BEST INTEREST.		SHEET: 24644	

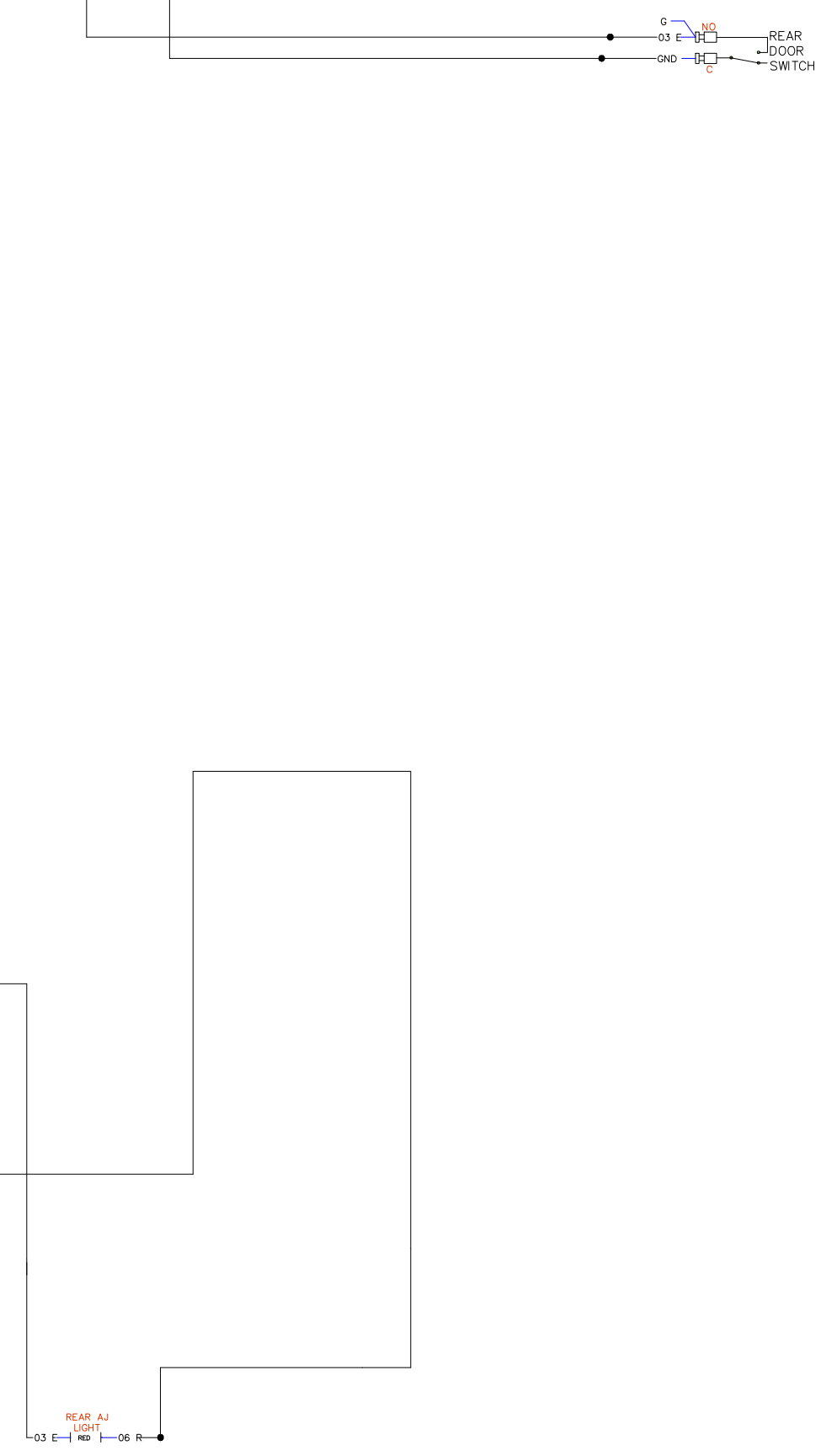
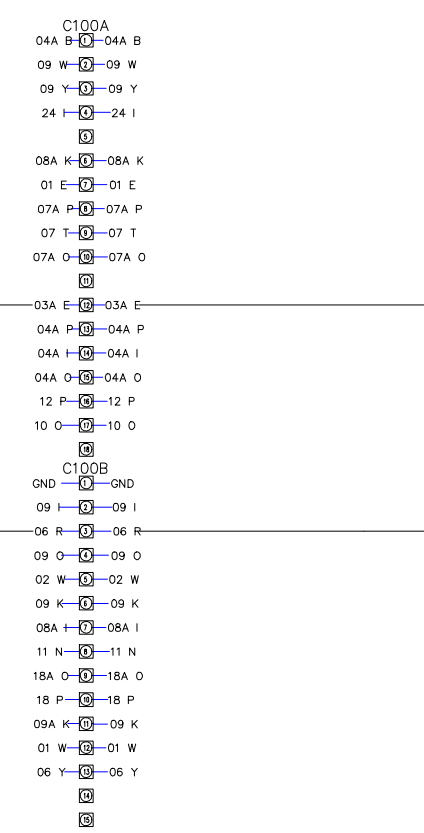
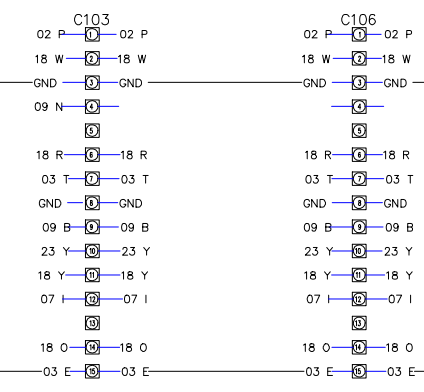
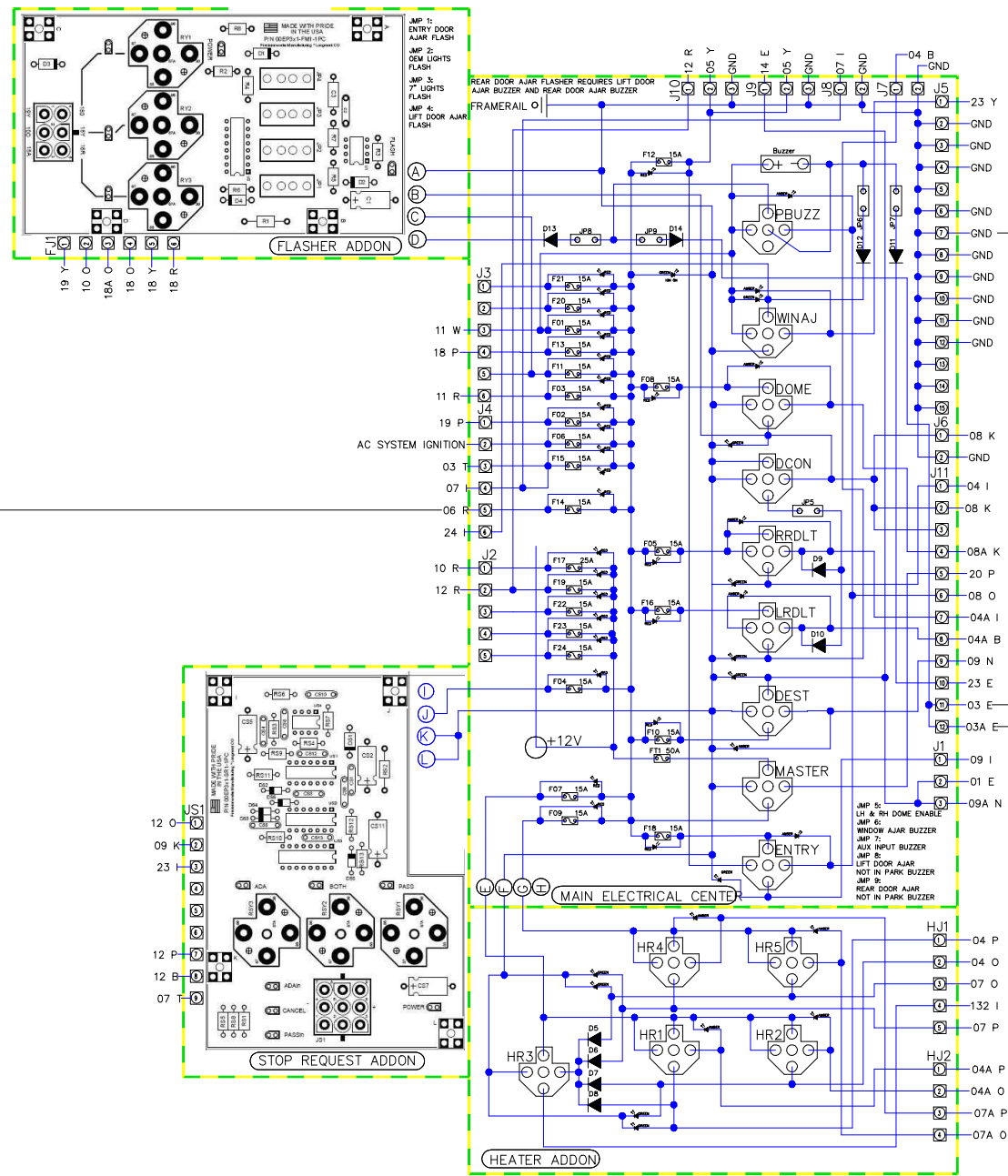

REV.	BY	DATE	DESCRIPTION	RELEASE #
2	FW	4/7/13	UPDATED MISC. TO HARNESS PRINTS	
3	FW	7/21/13	UPDATED MISC. TO HARNESS PRINTS	
4	FW	5/3/14	UPDATED ADDON CARDS	

COLOR CODES		LEGEND	
B	BLUE	—	CONNECTION
E	GREY	- - -	NO CONNECTION
C	GREEN	— —	DIODE
K	BLACK	— —	FUSE
I	PINK	— —	SPEAKER
N	BROWN	— —	SWITCH
O	ORANGE	— —	DUAL SWITCH
P	PURPLE	— —	RHEOSTAT
R	RED	— —	LED
T	TAN	— —	JUMPER
Y	YELLOW	— —	GROUND
W	WHITE	— —	CONNECTOR
		— —	12 WIRE LIGHT
		— —	13 WIRE LIGHT

PRECISIONWORKS MANUFACTURING		TITLE: Rear_door	
THIS DRAWING IS THE PROPERTY OF PRECISIONWORKS MANUFACTURING AND IS NOT TO BE DUPLICATED OR USED IN ANY WAY DETRIMENTAL TO THEIR BEST INTEREST.			
MATERIAL SPEC:	SCALE:	RELEASE NO. DATE:	DWG. NO. SHEET:
Champion	NTS	12/26/2013	24644

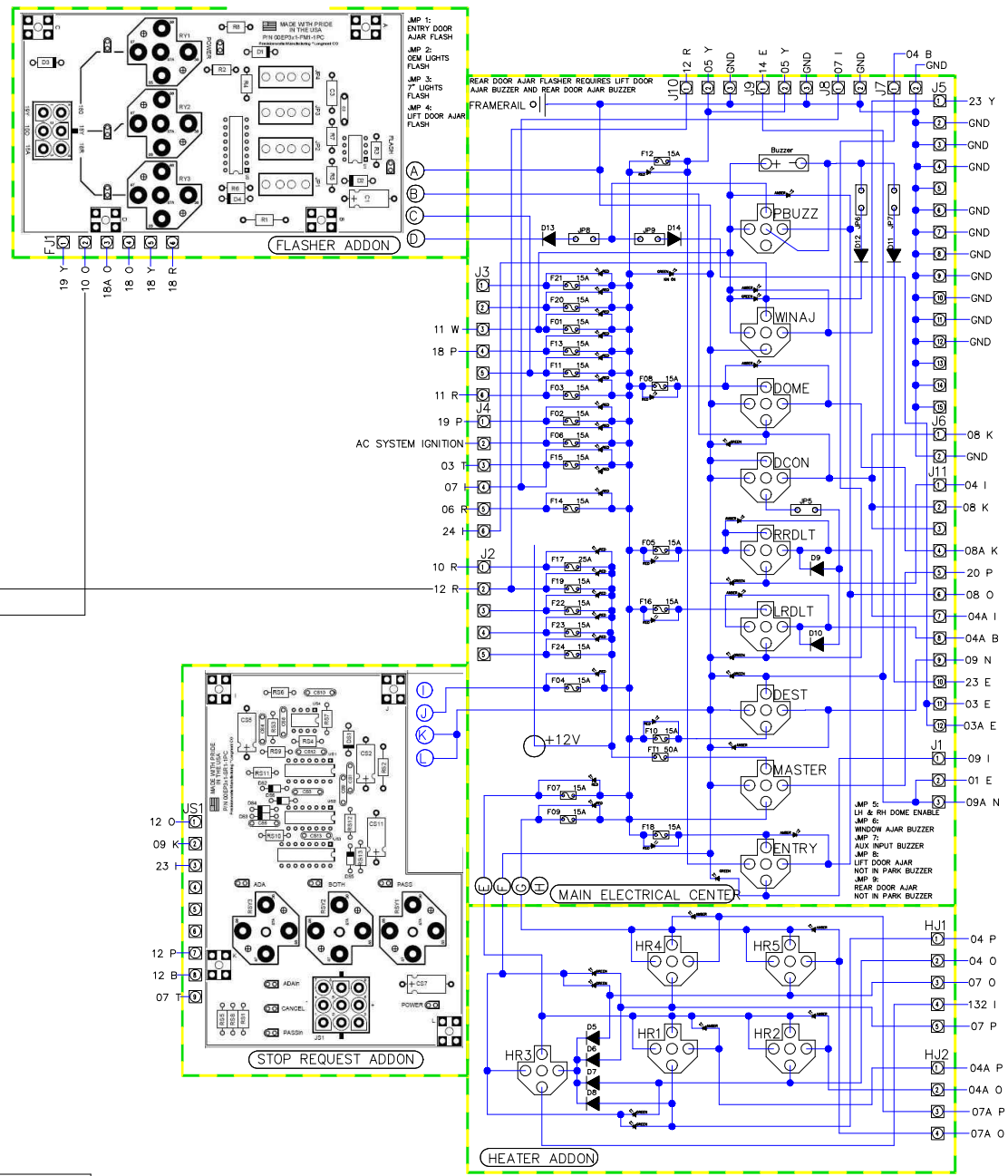

REVISIONS			
REV	BY	DATE	DESCRIPTION
C	PW	8/1/13	UPDATED MISC TO HARNESS PRINTS
B	PW	7/21/08	UPDATED MISC TO HARNESS PRINTS
A	PW	5/5/08	UPDATED ADDON CARDS

COLOR CODES	
B	BLUE
E	GREY
G	GREEN
K	BLACK
I	PINK
N	BROWN
O	ORANGE
P	PURPLE
R	RED
T	TAN
Y	YELLOW
W	WHITE

LEGEND	
(Symbol)	CONNECTION
(Symbol)	NO CONNECTION
(Symbol)	DIODE
(Symbol)	FUSE
(Symbol)	SPEAKER
(Symbol)	SWITCH
(Symbol)	DUAL SWITCH
(Symbol)	RHEOSTAT
(Symbol)	LED
(Symbol)	JUMPER
(Symbol)	GROUND
(Symbol)	CONNECTOR
(Symbol)	2 WIRE LIGHT
(Symbol)	3 WIRE LIGHT

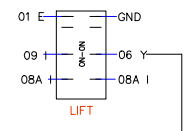
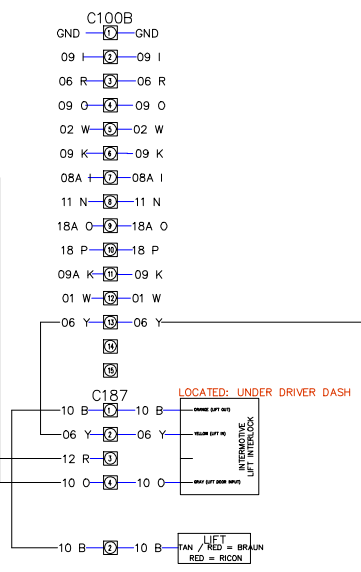

PRECISIONWORKS MANUFACTURING		TITLE: Gateway	
190 3TH AVE E-4 LONGMONT, CO 80501		ADDITIONAL INFO:	
MATERIAL SPEC:		REV: C	RELEASE NO. DWG NO. 24644
MODEL: Champion	SCALE: NTS	DATE: 12/26/2013	SHEET:

DOME LIGHT HARNESS

DOME LIGHT HARNESS

FRONT CAP HARNESS

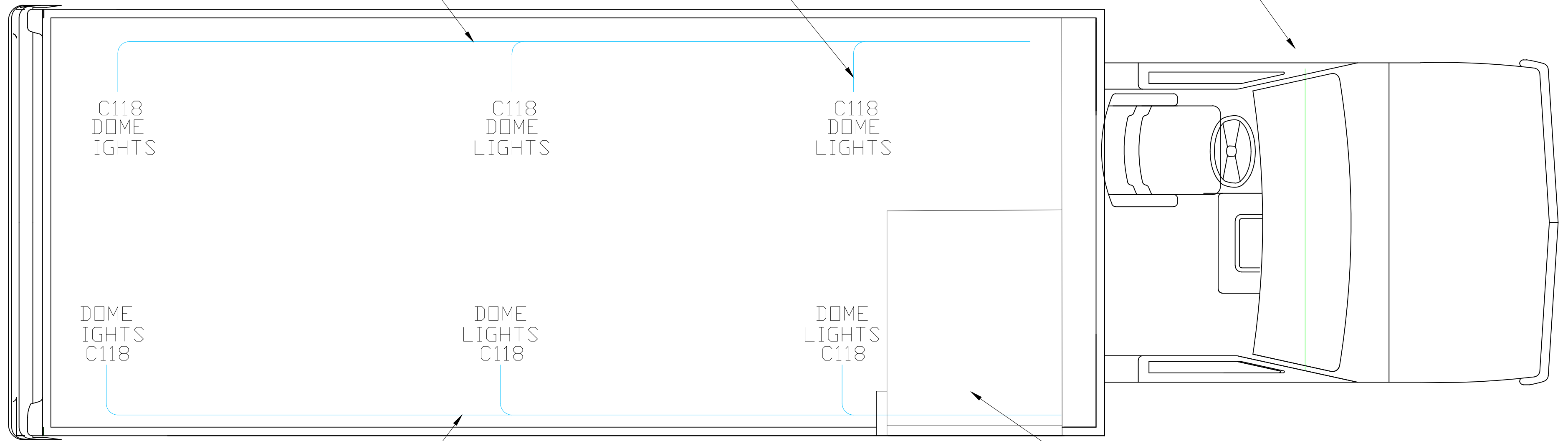

DOME LIGHT HARNESS

C110,
C154,
C157

REV.	BY	DATE	DESCRIPTION	RELEASE #
C	PH	8/1/13	UPDATED MISC TO HARNESS PRINTS	
B	PH	7/21/08	UPDATED MISC TO HARNESS PRINTS	
A	PH	5/5/08	UPDATED ADDON CARDS	

COLOR CODES	
B	BLUE
E	GREY
G	GREEN
K	BLACK
L	PINK
N	BROWN
O	ORANGE
P	PURPLE
R	RED
T	TAN
Y	YELLOW
W	WHITE

LEGEND	
(Symbol)	CONNECTION
(Symbol)	NO CONNECTION
(Symbol)	DIODE
(Symbol)	FUSE
(Symbol)	SPEAKER
(Symbol)	SWITCH
(Symbol)	DUAL SWITCH
(Symbol)	RHEOSTAT
(Symbol)	LED
(Symbol)	JUMPER
(Symbol)	GROUND
(Symbol)	CONNECTOR
(Symbol)	2 WIRE LIGHT
(Symbol)	3 WIRE LIGHT

PRECISIONWORKS MANUFACTURING	TITLE Dome_Lights
<small>THIS DRAWING IS THE PROPERTY OF PRECISIONWORKS MANUFACTURING AND IS NOT TO BE DUPLICATED OR USED IN ANY WAY DEEMED HARMFUL TO THEIR BEST INTERESTS.</small>	
MATERIAL SPEC: Champion	RELEASE NO. 24644 DATE 12/26/2013 SHEET

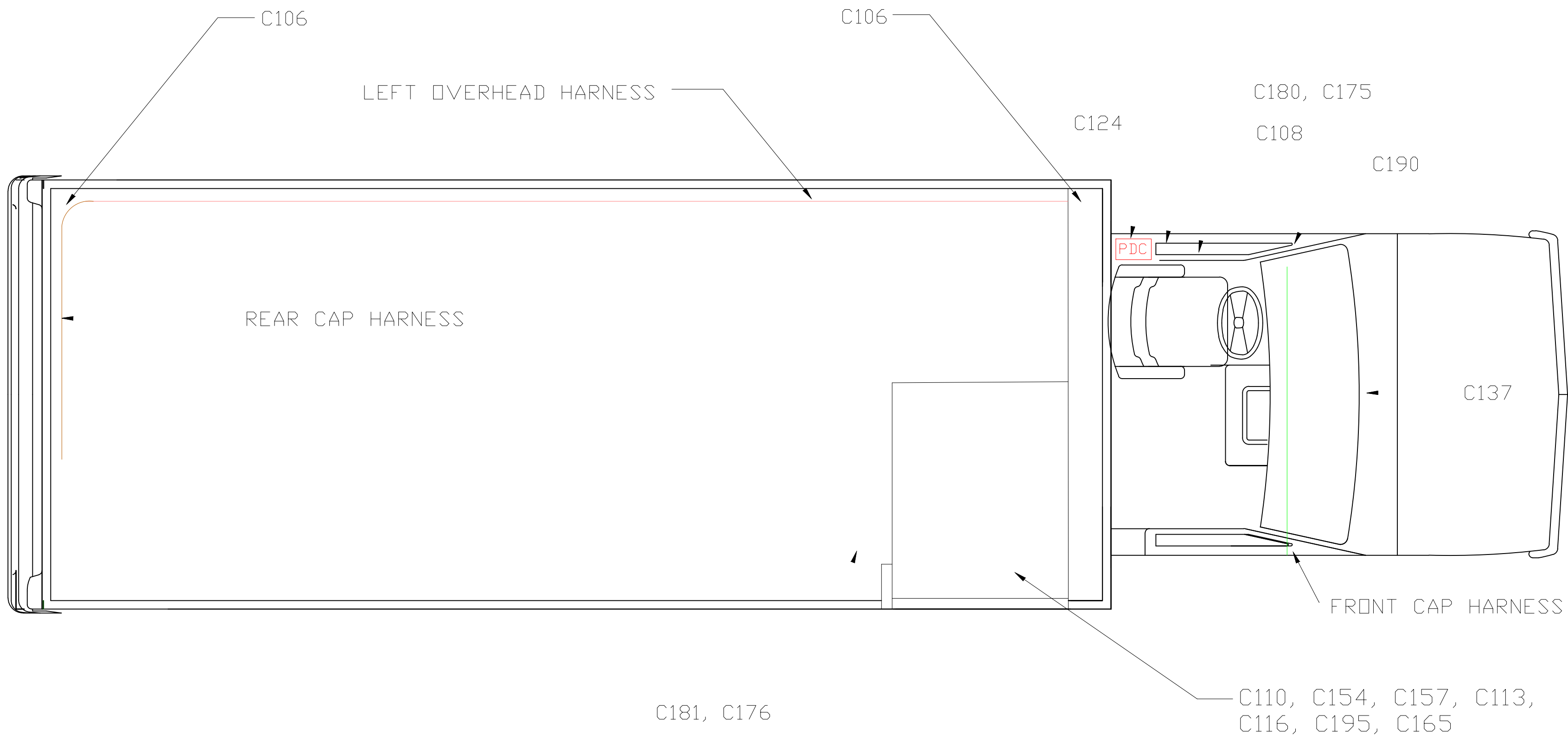

REVISIONS			
REV	BY	DATE	DESCRIPTION
C	FW	8/7/13	UPDATED MSC TO HARNESS PRINTS
B	FW	7/27/08	UPDATED MSC TO HARNESS PRINTS
A	FW	5/5/08	UPDATED ADDON CARDS

COLOR CODES	
B	BLUE
G	GREY
Q	GREEN
K	BLACK
I	PINK
N	BROWN
O	ORANGE
P	PURPLE
R	RED
T	TAN
Y	YELLOW
W	WHITE

LEGEND	
—	CONNECTION
---	NO CONNECTION
⏏	DIODE
⏏	FUSE
⏏	SPEAKER
⏏	SWITCH
⏏	DUAL SWITCH
⏏	RHEOSTAT
⏏	LED
⏏	JUMPER
⏏	GROUND
⏏	CONNECTOR
⏏	2 WIRE LIGHT
⏏	3 WIRE LIGHT

PRECISIONWORKS MANUFACTURING 120 8TH AVE LONGMONT, CO 80501		TITLE: Harness	
THIS DRAWING IS THE PROPERTY OF PRECISIONWORKS MANUFACTURING AND IS NOT TO BE DUPLICATED OR USED IN ANY WAY DETRIMENTAL TO THEIR BEST INTEREST.			
MATERIAL SPEC:	SCALE:	RELEASE NO:	DWG NO: 24644
MODEL: Champion	SCALE: NTS	DATE: 12/26/2013	SHEET

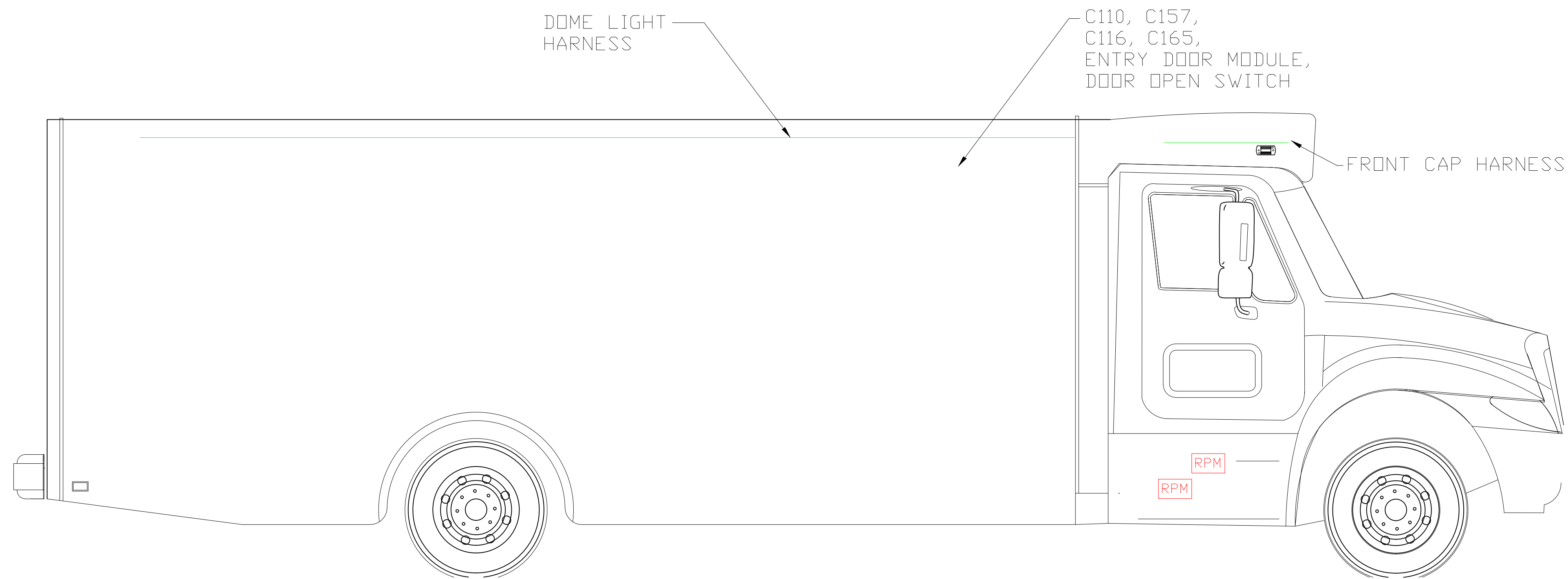

REV.	BY	DATE	DESCRIPTION	RELEASE #
C	PW	8/1/13	UPDATED MISC TO HARNESS PRINTS	
B	PW	7/21/08	UPDATED MISC TO HARNESS PRINTS	
A	PW	5/5/08	UPDATED ADDON CARDS	

COLOR CODES	
B	BLUE
E	GREY
G	GREEN
K	BLACK
I	PINK
N	BROWN
O	ORANGE
P	PURPLE
R	RED
T	TAN
Y	YELLOW
W	WHITE

LEGEND	
—	CONNECTION
—	NO CONNECTION
—	DIODE
—	FUSE
—	SPEAKER
—	SWITCH
—	DUAL SWITCH
—	RHEOSTAT
—	LED
—	JUMPER
—	GROUND
—	CONNECTOR
—	2 WIRE LIGHT
—	3 WIRE LIGHT

PRECISIONWORKS MANUFACTURING 120 9TH AVE. E-4 LONGMONT, CO 80501		TITLE: Entry_DR_Harness	
THIS DRAWING IS THE PROPERTY OF PRECISIONWORKS MANUFACTURING AND IS NOT TO BE DUPLICATED OR USED IN ANY WAY DETRIMENTAL TO THEIR BEST INTEREST.		ADDITIONAL INFO:	
MATERIAL SPEC:		SIZE: C	RELEASE NO. DWG NO. 24644
MODEL: Champion		SCALE: NTS	DATE: 12/26/2013 SHEET:

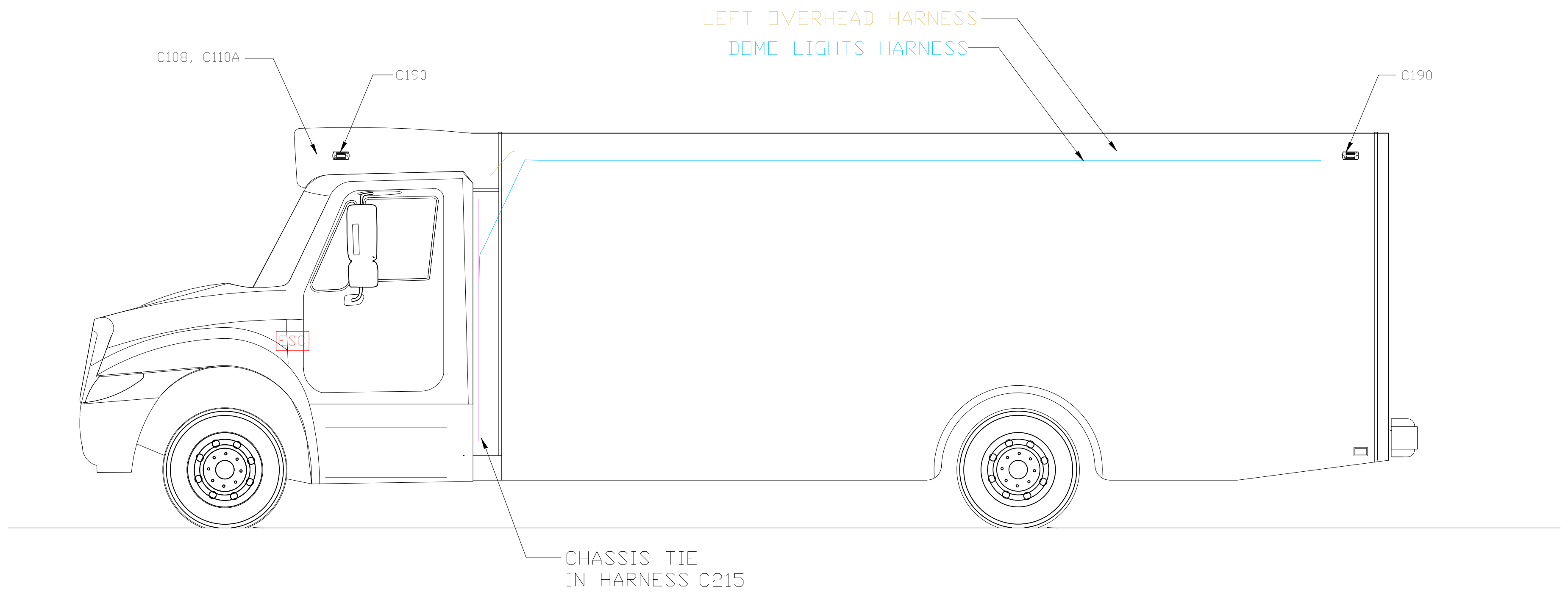

REV.	BY	DATE	DESCRIPTION	RELEASE #
C	PW	8/1/13	UPDATED MISC TO HARNESS PRINTS	
B	PW	7/21/08	UPDATED MISC TO HARNESS PRINTS	
A	PW	5/5/08	UPDATED ADDON CARDS	

COLOR CODES	
B	BLUE
E	GREY
G	GREEN
K	BLACK
I	PINK
N	BROWN
O	ORANGE
P	PURPLE
R	RED
T	TAN
Y	YELLOW
W	WHITE

LEGEND	
○	CONNECTION
○	NO CONNECTION
⬮	DIODE
⬮	FUSE
⬮	SPEAKER
⬮	SWITCH
⬮	DUAL SWITCH
⬮	RHEOSTAT
⬮	LED
⬮	JUMPER
⬮	GROUND
⬮	CONNECTOR
⬮	2 WIRE LIGHT
⬮	3 WIRE LIGHT

PRECISIONWORKS MANUFACTURING 100 20TH AVE E LONGMONT, CO 80501		TITLE: Heater_harness	
THIS DRAWING IS THE PROPERTY OF PRECISIONWORKS MANUFACTURING AND IS NOT TO BE DUPLICATED OR USED IN ANY MAY BE DETRIMENTAL TO THEIR BEST INTERESTS			
MATERIAL SPEC:		SCALE:	DATE:
Champion		NTS	12/26/2013
		DWG No.	SHEET
		24644	

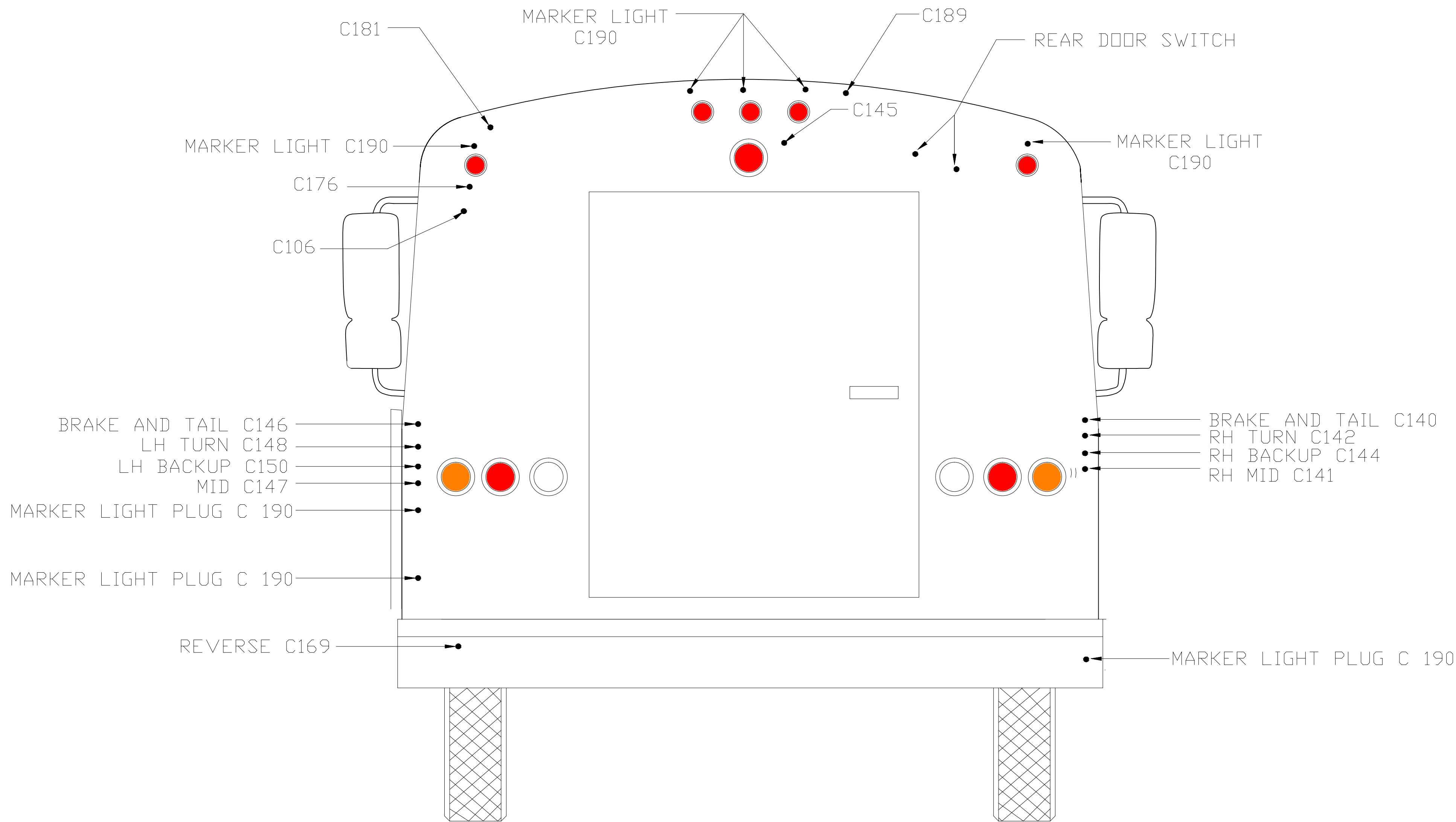

REV.	BY	DATE	DESCRIPTION	RELEASE #
C	PW	8/7/13	UPDATED MSC TO HARNESS PRINTS	
B	PW	7/21/08	UPDATED MSC TO HARNESS PRINTS	
A	PW	5/5/08	UPDATED ADDON CARDS	

COLOR CODES	
B	BLUE
E	GREY
G	GREEN
K	BLACK
I	PINK
N	BROWN
O	ORANGE
P	PURPLE
R	RED
T	TAN
Y	YELLOW
W	WHITE

LEGEND	
(Symbol)	CONNECTION
(Symbol)	NO CONNECTION
(Symbol)	DIODE
(Symbol)	FUSE
(Symbol)	SPEAKER
(Symbol)	SWITCH
(Symbol)	DUAL SWITCH
(Symbol)	RHEOSTAT
(Symbol)	LED
(Symbol)	JUMPER
(Symbol)	GROUND
(Symbol)	CONNECTOR
(Symbol)	2 WIRE LIGHT
(Symbol)	3 WIRE LIGHT

PRECISIONWORKS MANUFACTURING 120 3RD AVE. E. 4 LONGMONT, CO 80501		TITLE: Rear_Lights	
THIS DRAWING IS THE PROPERTY OF PRECISIONWORKS MANUFACTURING AND IS NOT TO BE DUPLICATED OR USED IN ANY MANNER DETRIMENTAL TO THEIR BEST INTEREST.		ADDITIONAL INFO:	
MATERIAL SPEC:	SCALE:	RELEASE NO.:	DWG NO.:
Model:	NTS	DATE:	24644
Champion		12/26/2013	SHEET

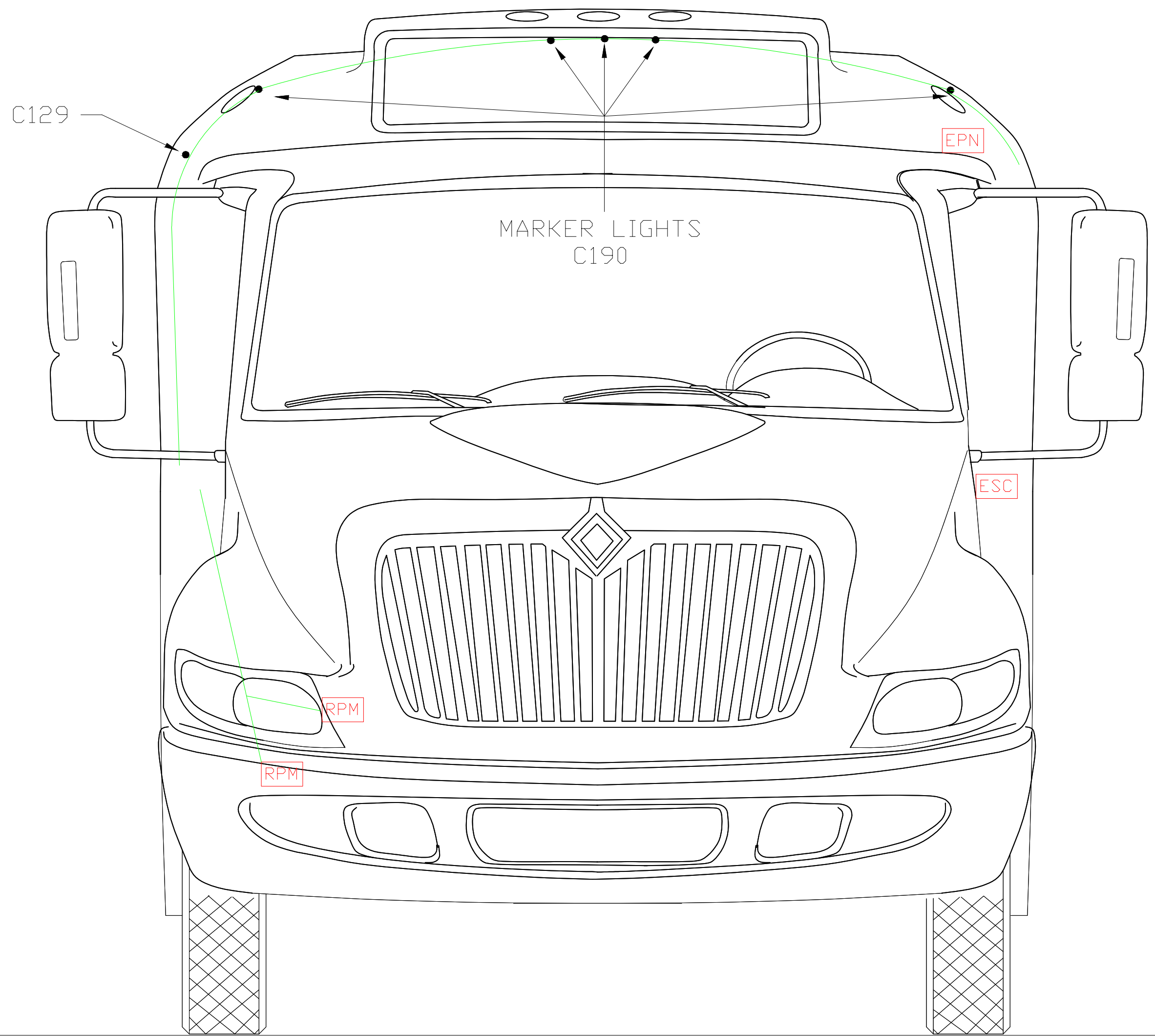

REV.	BY	DATE	DESCRIPTION	RELEASE #
C	PW	8/1/13	UPDATED MISC TO HARNESS PRINTS	
B	PW	7/21/08	UPDATED MISC TO HARNESS PRINTS	
A	PW	5/25/08	UPDATED ADDON CARDS	

COLOR CODES	
B	BLUE
E	GREY
G	GREEN
K	BLACK
I	PINK
N	BROWN
O	ORANGE
P	PURPLE
R	RED
T	TAN
Y	YELLOW
W	WHITE

LEGEND	
+	CONNECTION
-	NO CONNECTION
⊕	DIODE
⊖	FUSE
⊗	SPEAKER
⊘	SWITCH
⊕⊖	DUAL SWITCH
⊗⊘	RHEOSTAT
⊕⊖⊗	LED
⊕⊖⊗⊘	JUMPER
⊕⊖⊗⊘⊙	GROUND
⊕⊖⊗⊘⊙⊗	CONNECTOR
⊕⊖⊗⊘⊙⊗⊘	2 WIRE LIGHT
⊕⊖⊗⊘⊙⊗⊘⊙	3 WIRE LIGHT

PRECISIONWORKS MANUFACTURING 120 0TH AVE E44 LONGMONT, CO 80501		TITLE: Front_Lights	
THIS DRAWING IS THE PROPERTY OF PRECISIONWORKS MANUFACTURING AND IS NOT TO BE DUPLICATED OR USED IN ANY WAY DETRIMENTAL TO THEIR BEST INTERESTS.		ADDITIONAL INFO:	
MATERIAL SPEC:		REV: C	RELEASE NO: 24644
MODEL: Champion	SCALE: NTS	DATE: 12/26/2013	SHEET: